

ACCU-CHEK[®] *Sensor*

BLOOD GLUCOSE METER

Reference Manual





This product fulfills the requirements of Directive 98/79/EC on *in vitro* diagnostic medical devices.

Welcome

Thank you for selecting the Accu-Chek® Sensor System. Designed for ease of use, this system was produced in close association with diabetes health-care professionals, hospitals and, most importantly, people with diabetes.

The Accu-Chek Sensor System is intended for self-testing of glucose in capillary whole blood by persons with diabetes.

The lightweight, portable meter provides accurate results in seconds. When you dose the test strip, the meter measures your blood glucose level and displays your result. It's that simple.

Before using your Accu-Chek Sensor Meter or Accu-Chek® Softclix Lancet Device for the first time, please refer to the Quick Reference Guide included in this pack. Should you require further information, please study this user's manual. Please forward your completed warranty card immediately to Roche Diagnostics.

If you have any questions or inquiries, please call Roche Diagnostics.

Contents

| | |
|--|-------------|
| About the Accu-Chek Sensor Meter | v |
| Special Features | vii |
| About the Accu-Chek Sensor Comfort Test Strip | viii |
| Inserting the Battery | 1 |
| Battery Symbol on the Display | 2 |
| Setting the Beeper, Time, Date, Year, and Hypo Flag | 4 |
| Turning the Beeper On or Off | 4 |
| Setting the Time, Date and Year | 6 |
| Setting the Hypo Flag | 8 |
| Coding/Calibrating Your Meter | 9 |
| Testing | 11 |
| Gathering Supplies | 11 |
| Performing a Test | 11 |
| Marking a Result with a Flag, Asterisk (*) | 16 |
| Understanding Your Test Results | 17 |
| Do's and Don'ts | 18 |
| Proper Test Strip Appearance | 19 |
| Using Memory | 20 |
| Quality Control Checks | 22 |
| Performing a Quality Control Check | 24 |
| Understanding Control Results | 27 |

| | |
|--|-----------|
| Caring for Your Meter | 28 |
| Display Check | 28 |
| Cleaning | 28 |
| Storage and Handling | 29 |
| Note to Healthcare Professionals | 30 |
| Transferring Data | 31 |
| Quick Reference Display Guide | 32 |
| Memory Displays | 34 |
| Display Messages | 36 |
| Battery Displays | 36 |
| Quality Control Check Displays | 37 |
| Error Messages | 39 |
| Technical Data | 42 |
| Product Specifications | 43 |
| Product Safety Information | 45 |
| Warranty and Service Instructions | 46 |
| Supplies and Accessories | 47 |
| Index | 48 |
| Any Questions | 51 |

About the Accu-Chek® Sensor Meter

ON/OFF Button

Press to turn meter ON or OFF.

Serial Port

Used to transfer data.

Display

Shows blood glucose result, messages, and glucose results stored in memory.

Right and Left Buttons

Used for meter setup and review of memory.

Test Strip Slot

Insert test strip here.



About the Accu-Chek Sensor Meter

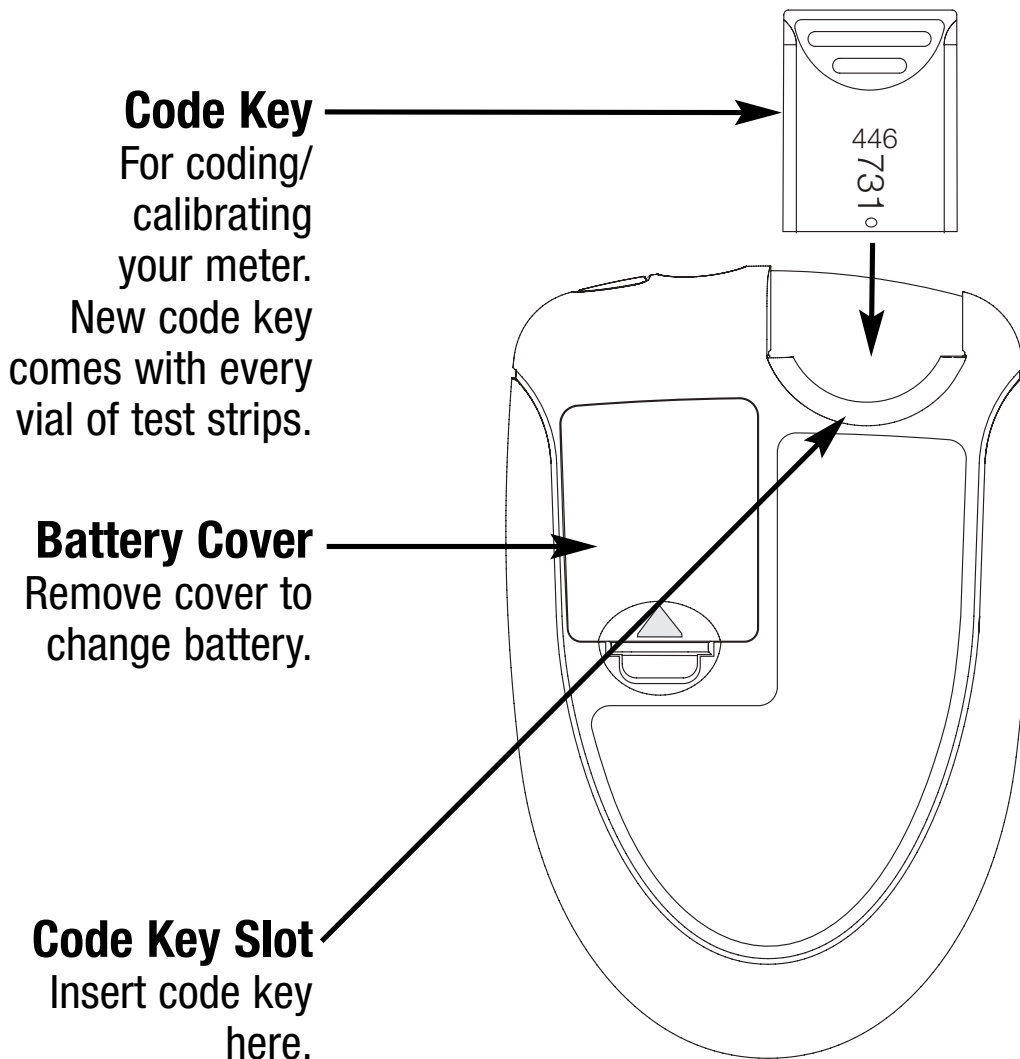

Special Features

Your meter is designed to store information important to you and your healthcare professional. The memory will store 480 readings.

Along with these readings, the meter can store additional important information. The hypo flag allows you to define your hypoglycemic level and receive a reminder whenever you obtain a blood sugar result below this level. See page 8 for additional information.

The meter also has a flag, or asterisk (*), that you can save in the memory with your blood sugar result. See page 16 for additional information on this feature.

The meter will also calculate 7, 14, and 30-day averages. You do not have to set the time and date for the meter to give you average calculations. See page 20 for specific information on averages.

About the Accu-Chek® Sensor Comfort Test Strip

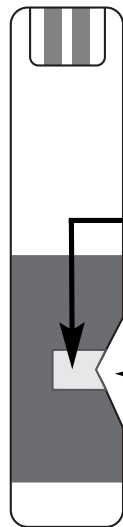

Electrodes

Insert strip with silver-coloured bars up and toward the meter.

Yellow Window

Do not apply blood on the top of the test strip.

Before Applying Blood –

This window should be completely yellow.

After Applying Blood –

This window should be completely filled with the blood drop.

Note: Any area of the strip can be touched and the glucose reading will not be affected.

Comfort Curve

Touch drop of blood here, to the edge of the strip.

Inserting the Battery

Your meter is shipped with one 3-volt battery type 2032 (CR 2032, DL 2032, or equivalent) that needs to be inserted before testing. The battery that comes with your meter can be found in the mesh pocket of your carrying case. Battery life will vary depending on usage, so always keep a spare on hand.

The meter saves battery power by automatically turning off after 90 seconds of non-use or 5 seconds after taking a strip out of the meter following a test. If the meter does automatically shut off, all tests in memory are saved.

Note: After changing the battery, your meter will prompt you to verify the time and date immediately after the battery is inserted. This occurs only if the time and date had been set previously on your meter.

1. Push the recessed plastic tab of the battery compartment forward (toward the arrow) to flip open the battery door.

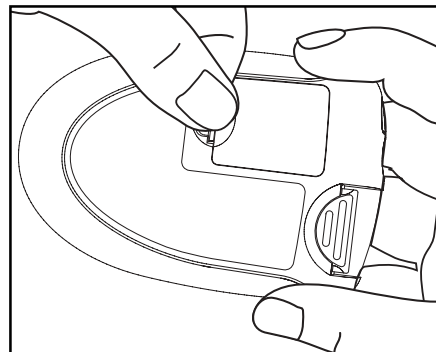

2. Insert the 3-volt battery (type 2032) into the compartment with “+” side facing you.

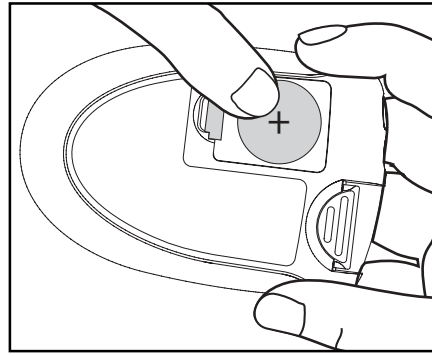

3. Snap battery cover back in place. If time and date feature was set previously, the meter will turn on automatically. Confirm that the time and date are set correctly. If time and date have not been set previously, wait 5 seconds, then turn meter ON. The meter beeps if the beeper is turned on.

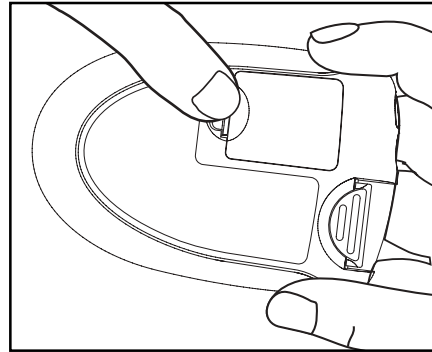

Battery Symbol on the Display

When a battery symbol appears on the display, your battery is weak and has only enough power to run a few more tests. Although the meter will still provide accurate results, you need to replace the battery as soon as possible.

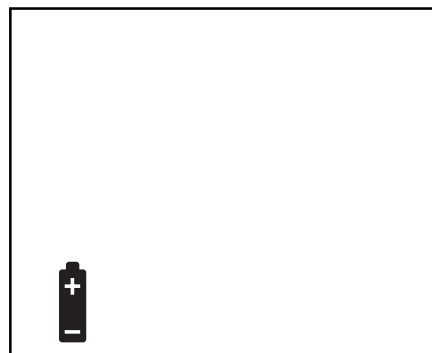

Battery is low.

If a flashing battery symbol appears on the display, the battery is nearly dead.

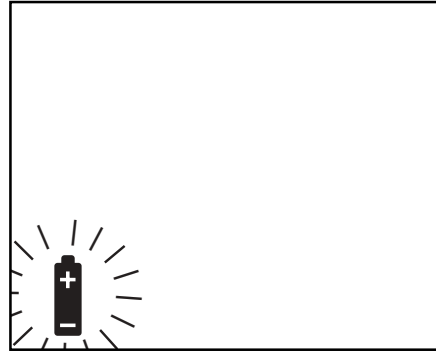

**Battery must be replaced
to continue testing.**

After changing the battery, your meter will prompt you to verify the time and date immediately after the battery is inserted, if time and date had previously been set. See ***Setting the Time, Date and Year*** on page 6.

Note: To retain the correct time and date settings, you will need to replace the battery before it is completely dead.

Please dispose of meter battery according to your local ordinances.

Setting the Beeper, Time, Date, Year, and Hypo Flag

Turning the Beeper On or Off

Does the beeper have to be turned on?

No, it is an optional feature. Turning the beeper on or off does not affect the test results. If the beeper is turned off, beeps that occur due to errors will still sound.

The meter is set to beep when:

- A strip is inserted
- Blood or control solution is applied to strip
- A result is displayed
- An error occurs while testing
- Buttons are pushed
- Battery is installed

If you do not want the beeper on, turn it off by following these steps:

1. Press and release the ON/OFF button to turn the meter ON.
2. Wait until the strip icon flashes or code and “---” appear before proceeding to step 3.

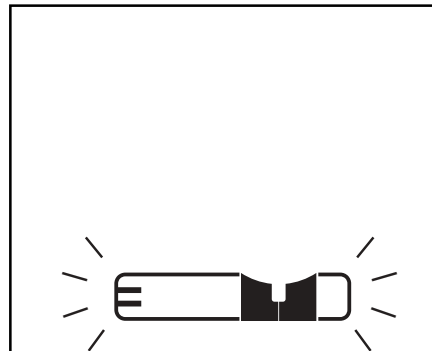

3. Press and hold down the ON/OFF button until “set” appears at the bottom of the screen. Release the ON/OFF button.

“On,” “set,” and the flashing beeper symbol appear on the display. The beeper is now on.

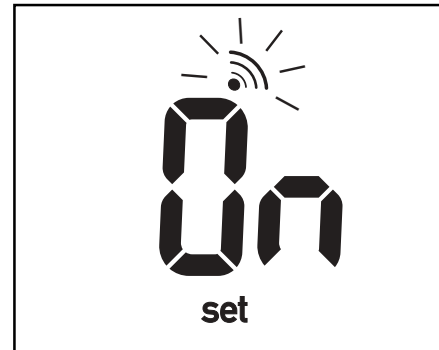

Note: You may leave the set mode at any time by pressing and holding the ON/OFF button. The settings you have entered will be saved.

4. Press and release the right or left arrow button.

“OFF,” “set,” and the beeper symbol appear on the display. The beeper is now off. To turn beeper back on, simply press and release the right or left arrow button again.

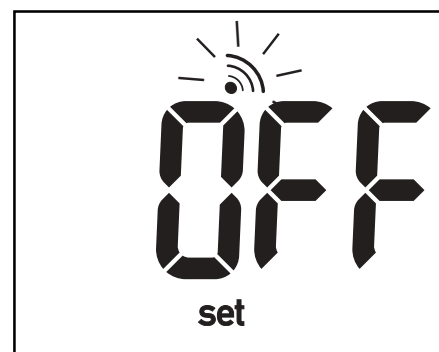
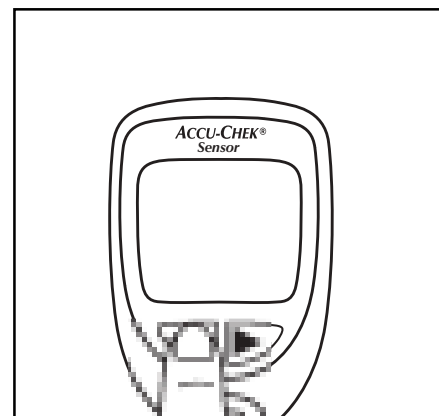

5. Press and hold down the ON/OFF button until strip icon is seen flashing or code and “---” appear to leave this function.

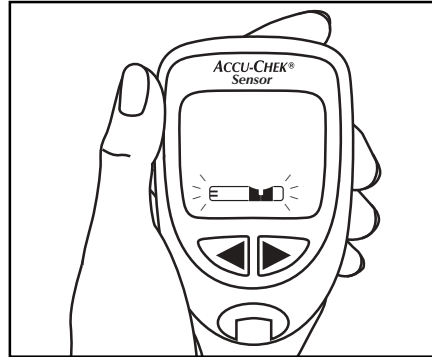

Setting the Time, Date and Year

Do I have to set the time and date?

Time and date should be set prior to testing if you plan to download the results into software or if you plan to review your memory to check when a test was done.

To set the time, date and year:

1. Press and release the ON/OFF button to turn the meter ON.
2. Wait until the strip icon flashes or code and “---” appear before proceeding to step 3.
3. Press and hold down the ON/OFF button until “set” appears at the bottom of the screen. Release the ON/OFF button.
4. Press and release the ON/OFF button to confirm beeper setting and move to set the time.

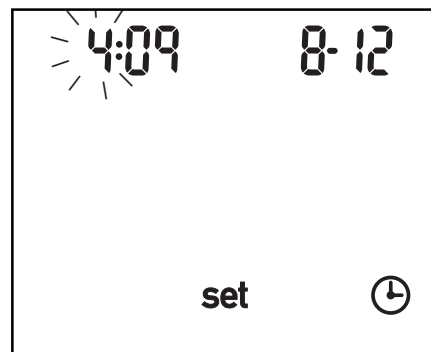
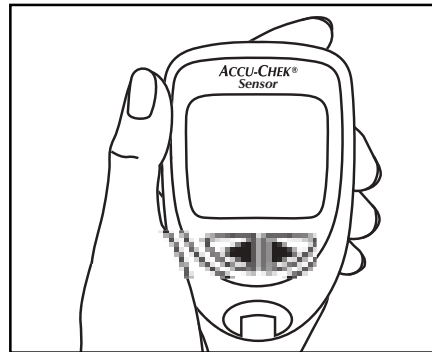

5. Press and release the ON/OFF button. The hour display flashes.
6. Press and release the right or left arrow button until the correct hour is displayed.
7. Press and release the ON/OFF button. The minute display flashes.
8. Press and release the right or left arrow button until the correct minute is displayed.
9. Press and release the ON/OFF button. The month display flashes.
10. Press and release the right or left arrow button until the correct month is displayed.
11. Press and release the ON/OFF button. The day display flashes.
12. Press and release the right or left arrow button until the correct day is displayed.
13. Press and release the ON/OFF button. The year display flashes.
14. Press and release the right or left arrow button until the correct year is displayed.
15. To leave this function, press and hold down the ON/OFF button until the flashing strip symbol or code and “---” are displayed.

Note: You may leave the set mode at any time by pressing and holding the ON/OFF button. The settings you have entered will be saved.

Setting the Hypo Flag

The hypo flag allows you to define your hypoglycemic level and receive a reminder whenever you obtain a blood sugar result below this level. You can set the hypo indicator level to any number between 60 and 80 mg/dL (3,3 and 4,4 mmol/L).

Important Note: Consult with your healthcare professional to set the hypo marker to compliment your therapy. Do not use the hypo marker as the only indicator of hypoglycemia. Rely upon your symptoms and directions from your healthcare professional.

To set the hypo flag:

1. Press the ON/OFF button to turn the meter on.
2. Wait until the strip icon or code and “---” flash before proceeding to step 3.
3. Press and hold down the ON/OFF button until “set” appears at the bottom of the screen. Release the ON/OFF button.
4. Repeatedly press and release the ON/OFF button until “hypo” flashes and “OFF” and “set” appear on the display.

Note: the meter is factory set with the hypo flag in the off position.

5. Press and release the right or left arrow button to turn ON the hypo flag.
6. Briefly press and release the ON/OFF button. “Hypo” flashes, and the current hypo indicator setting, “set,” “mg/dL” or “mmol/L” appear on the display.

7. Press and release the right or left arrow button to adjust the hypo flag setting.
8. To leave this function, press and hold down the ON/OFF button until the flashing strip symbol or code and “---” are displayed.

Coding/Calibrating Your Meter

What is coding/calibrating, and when is it necessary?

Before you use your meter for the first time and every time you open a new box of test strips, you need to set the meter to “match” the strips. This is called coding/calibrating.

To ensure accuracy of your blood glucose monitoring system, you must change your code key with each new box of test strips. Each code key provides your meter with the specific information that your meter needs to accurately measure your blood glucose. Do not use code keys with your Accu-Chek Sensor Meter from any test strip manufacturer or system other than the Accu-Chek Sensor System from Roche Diagnostics. Use of other manufacturers' code keys may result in erroneous results with your system.

A code key is properly inserted when it snaps into place. You will need to insert a new code key:

- Whenever you open a new box of strips.
- Whenever either one of these displays appear:

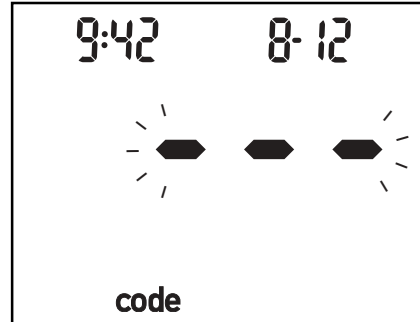
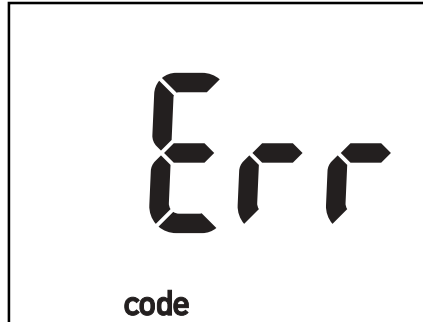

1. Make sure meter is turned off. Turn meter over so you are looking at the back. Remove old code key if one is installed.
2. Insert new code key until it snaps into place.

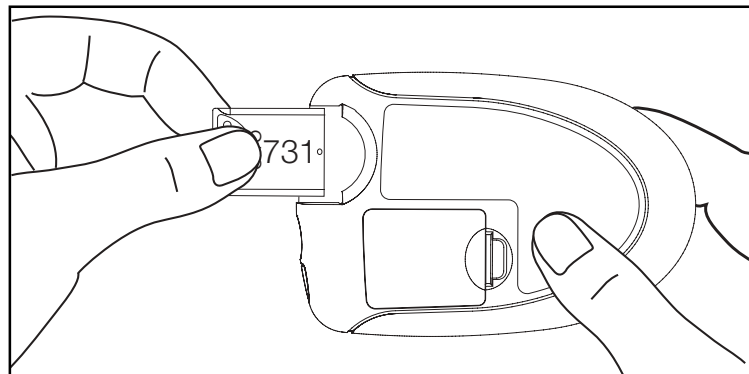

3. Turn meter ON. A 3-digit code number appears. This number must match the code number on your vial of test strips. If it does not, repeat steps 1–3.

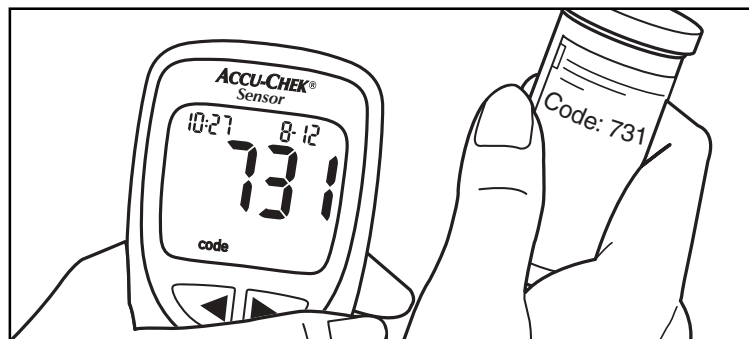

Testing

Gathering Supplies

To begin testing, you will need the following items:

- **Accu-Chek® Sensor Meter**
- **Accu-Chek® Sensor Comfort Test Strips**
- **Accu-Chek® Softclix Lancet**
- **Accu-Chek® Softclix Lancing Device**

Performing a Test

1. Wash your hands in warm, soapy water. Rinse well and dry completely. Warming fingers can increase blood flow.
2. Load lancet device according to manufacturer's instructions.

 **To reduce the risk of infection, change lancet with each test.**

3. Remove new test strip from vial. **Be sure to tightly replace vial cap after removing test strip.**

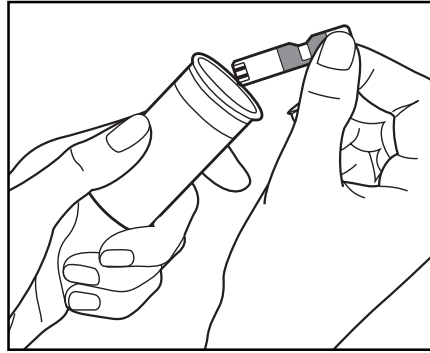

4. Within 3 minutes, insert test strip into test strip slot with silver-coloured bars facing up and toward the meter.

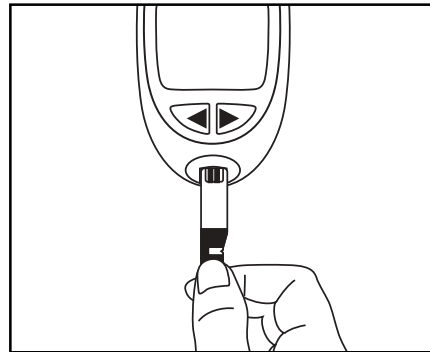

The meter turns on automatically.

Check that the code number on the meter matches the code on the vial of test strips you are using.

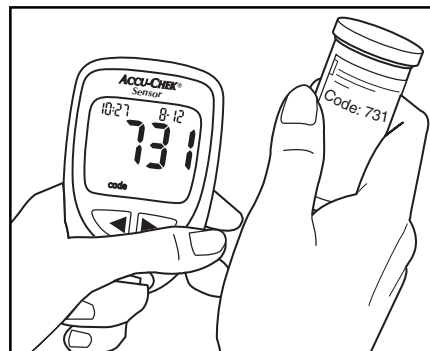

When the blood drop symbol flashes, you are ready to perform a test.

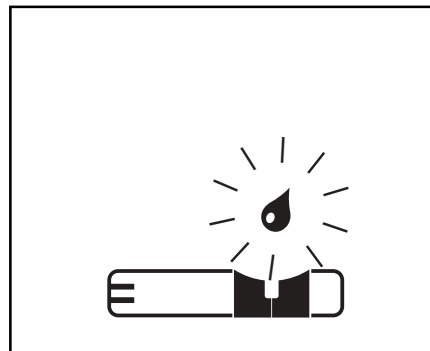

5. Let your arm hang down at your side briefly to allow blood to flow to your fingertips.
6. Grasp your finger just below the joint closest to the fingertip, and squeeze for 3 seconds.
7. Obtain blood sample. Use the lancet to obtain a drop on the side of your finger. Do not obtain the drop from the pad of your finger. To perform the test, obtain a small drop of blood resting on your finger.
8. ***Touch and hold drop of blood to the edge of the strip within the curve. Do not place the blood drop on top of the strip.***

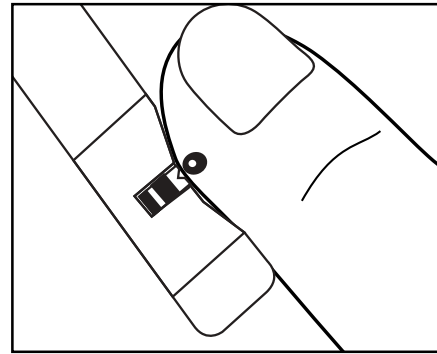

The blood will be drawn into the strip automatically. If beeper is turned on, meter will beep to let you know the test is beginning. Hold your finger to the edge of the strip until the yellow window is completely filled with blood.

What if I still see yellow on the test strip?

- **If less than 15 seconds** have passed, a second drop of blood may be applied.
- **If more than 15 seconds** have passed, remove the strip and repeat test with a new strip.

9. When blood is applied to strip, an hourglass flashes on the display until measurement is completed. Result appears.



10. The blood glucose result is displayed in mg/dL or mmol/L.

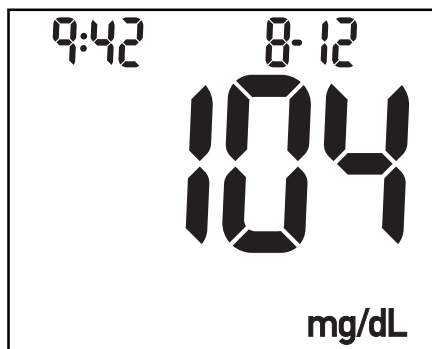

or

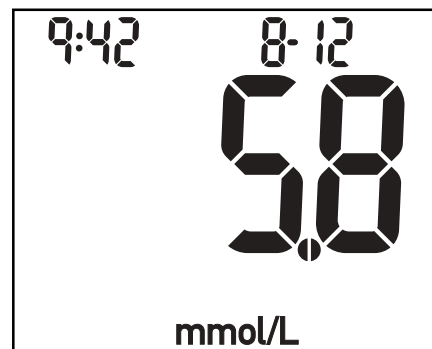

Your result is automatically recorded in the meter's memory. You may also want to record the glucose value in your Record Book or Diary.



Note: For instructions on how to store a result in memory with a general flag (asterisk), refer to **Marking a Result with a Flag, Asterisk (*)** on page 16.

11. Remove test strip from meter. Discard the strip and lancet in a puncture-proof container with a lid. If you have completed your testing, turn the meter OFF, or the meter will automatically turn off 5 seconds after removing the strip.

If HI is displayed, your blood glucose result may be higher than 600 mg/dL (33,3 mmol/L) (refer to your test strip package insert or the section ***Understanding Your Test Results*** on page 17).

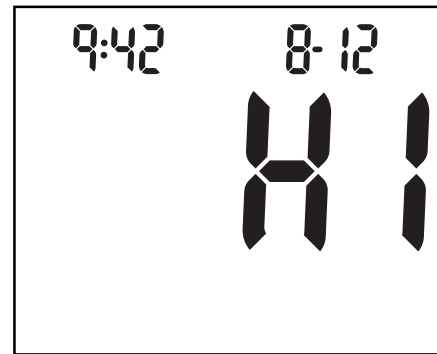

If LO is displayed, your blood glucose result may be lower than 10 mg/dL (0,6 mmol/L) (refer to your test strip package insert or the section ***Understanding Your Test Results*** on page 17).

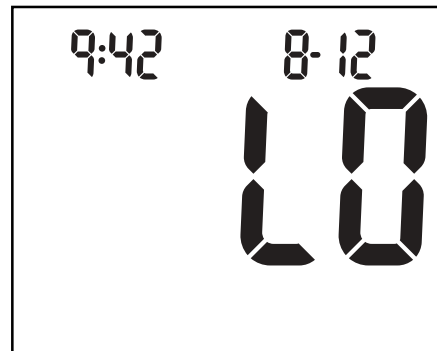

Marking a Result with a Flag, Asterisk (*)

This feature allows you to perform a test and mark the result with a flag (asterisk) to be stored in memory. Each result flagged with the asterisk will have special meaning only to you. For your healthcare professional, you should record the meaning along with your reading in your Record Book or Diary. An example includes using the asterisk to mark a result taken immediately after a meal.

To mark a result with a flag (asterisk):

1. Perform blood glucose test and obtain result.

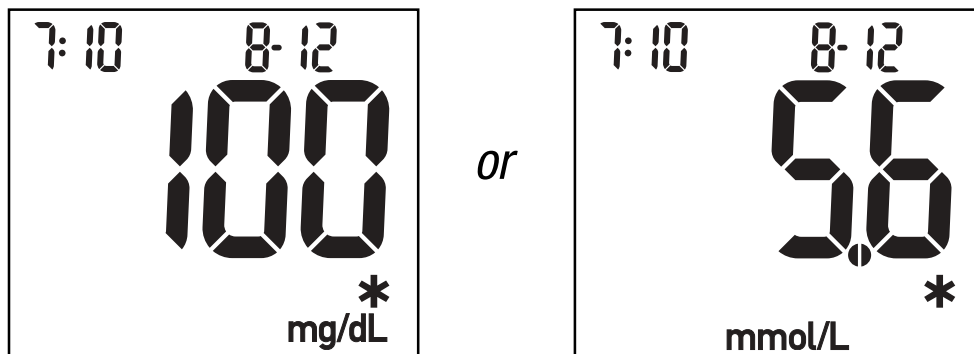

2. **While the strip is still in the meter**, press and release the right or left arrow button. An asterisk will appear on the lower right corner of the screen.
3. Remove the strip from the meter, turn the meter OFF, or the meter will automatically turn off 5 seconds after removing the strip. The result will be stored automatically with the asterisk in memory.

Understanding Your Test Results

If your blood glucose result seems unusually high, low, or inconsistent with your previous results or glucose trends and does not reflect the way you feel, check the following:

- Does the test strip number on the vial match the code number on the meter?
- Was the blood sample applied to the test strip within 3 minutes of removing it from the vial?
- Was the size of the blood sample sufficient?
- Was the test strip vial cap tightly sealed?
- Was the test strip used before the expiration date?
- Were the test strips stored at extreme temperatures such as in the car during very cold or hot weather?
- Were the test strips stored in areas of high humidity such as the kitchen or the bathroom?

Then run a quality control check with your glucose control solutions and a new test strip. (See page 22, ***Quality Control Checks***.) If the control result is within the acceptable range, review proper testing procedure and repeat your blood glucose test with a new test strip. If your blood glucose value is still inconsistent with your previous results, glucose trends, or how you feel, please contact your doctor. Follow the advice of your doctor before you change your therapy.

Do's and Don'ts

DO:

- **TIGHTLY REPLACE VIAL LID IMMEDIATELY AFTER REMOVING A TEST STRIP.**
- Make sure code number on meter matches code number on strip vial label.
- Keep meter clean.
- Store strips in the original vial.

DON'T:

- Store strips outside original vial.
- Use expired test strips.
- Use code key from another blood glucose system.
- Store meter or strips in extreme temperatures.
- Store meter in damp or humid areas.
- Insert any object other than a test strip into strip slot.
- Remove or insert code key while meter is on.
- Test with meter placed on hot or cold surfaces.

Proper Test Strip Appearance

Although only a small amount of blood is needed, it is very important that you put enough blood on your test strip so that the entire yellow window is filled with blood. This ensures that your meter can produce accurate and reliable results.

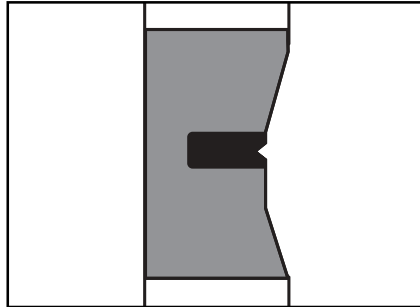

This strip has the correct amount of blood.

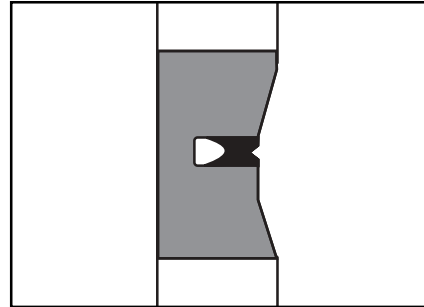

Notice that the left side of the yellow window is not completely filled with blood. This strip has too little blood and may produce an error message (or an inaccurate result).

Very small amounts of blood may give you an error message or an inaccurate result (see *Error Messages* on page 39). Repeat the test.

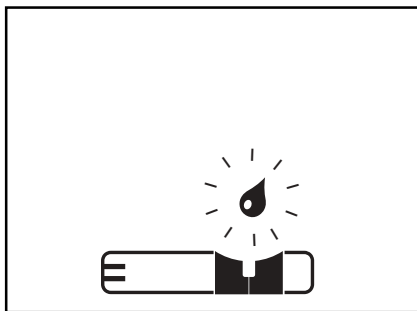

If this display remains after the blood drop is applied, then your drop was too small. Reapply a larger drop of blood.

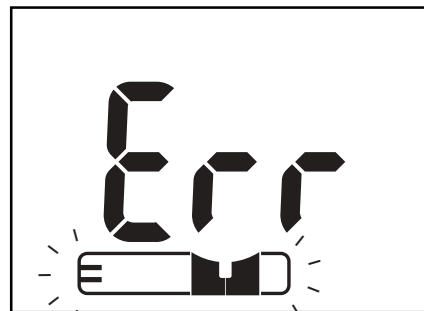

This error display may appear at the end of the test and you will not get a blood glucose result. Remove test strip and retest with a new strip using a larger drop of blood.

Using Memory

The meter automatically stores 480 glucose results, letting you review them in order from the most recent to the oldest. If you have set the time/date feature, the time and date of the results are also displayed. If time and date are not set, each result is marked with a number according to how it falls in sequence.

If the memory is full and a new result is added, the meter deletes the oldest result. Results stored in memory are not lost when you replace the battery. However, to retain the correct time and date settings, you must replace the battery before it is completely dead.

The Accu-Chek Sensor Meter also calculates 7, 14, and 30-day averages. You do not have to set the time and date for the meter to give you average calculations.

HI or LO results (results outside of the meter's reading range) and results marked as a control are not included in averages. If a HI or LO result is detected in memory "7 day ave," "14 day ave," or "30 day ave" flashes on the display.

If you perform a control test without marking it as a control, it appears like a blood glucose result in memory. It will also be included in the 7, 14, and 30-day averages.

To recall results and averages stored in memory:

1. Press and release the right or left arrow button to enter memory recall mode. If a code key is installed, the code number appears briefly,

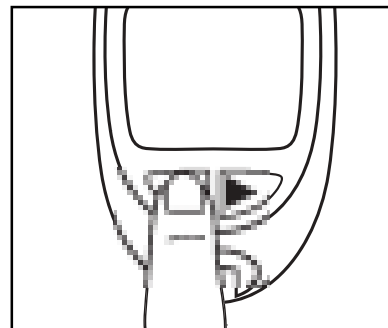

followed by the most recent result stored in memory. If no code key is installed, code and “---” appear. Press and release the right or left arrow button again to enter memory recall mode.

2. Once in the memory mode:
Press the left arrow button to view individual results in memory,

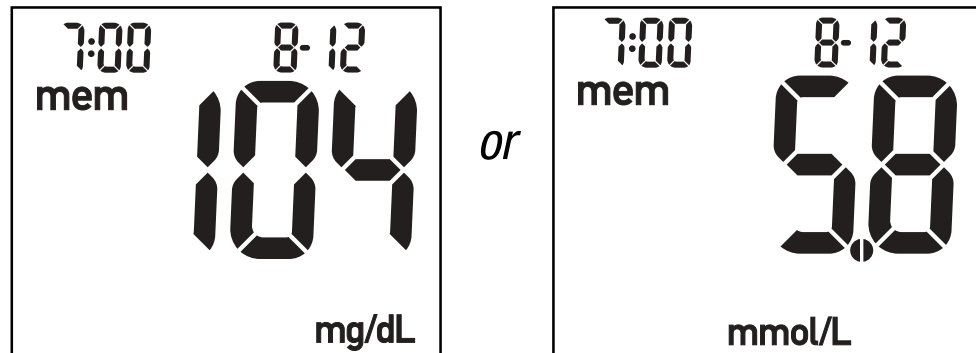

Or

Press the right arrow button to review, in sequence 7, 14, and 30-day averages.

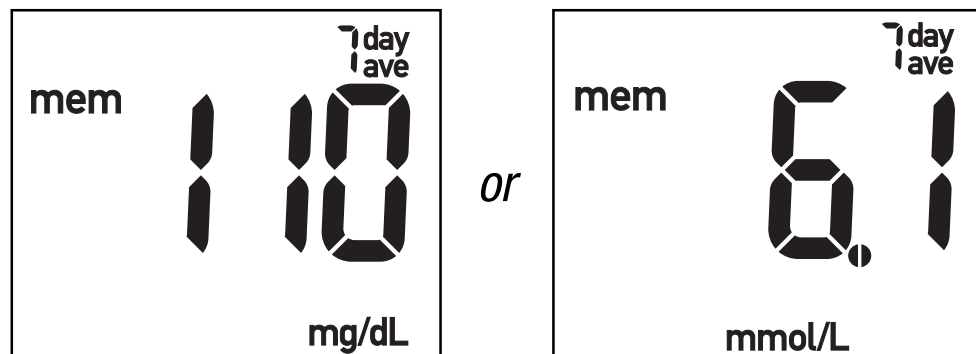

Note: Press and hold down the right or left arrow button to quickly scroll through results.

3. Turn meter OFF.

Quality Control Checks

What are quality control checks?

They ensure that you are doing a test correctly and that your system is working properly.

When should I check my meter?

- If you leave the cap off the vial of test strips.
- Before using your meter for the first time.
- When you open a new vial of test strips.
- If you drop the meter.
- Whenever your result does not agree with the way you feel.
- If you have repeated a test, and the blood glucose result is still lower or higher than expected.
- When you want to check the performance of the meter and test strip.

To do a quality control check, you need:

- Accu-Chek® Sensor Comfort Glucose Control Solutions (Level 1 and Level 2)
- Accu-Chek® Sensor Comfort Test Strips

Note: When you open a new bottle of glucose control solution, write the date on the label. Opened bottles of glucose control solution are good for three months or until the expiration date, whichever comes first.

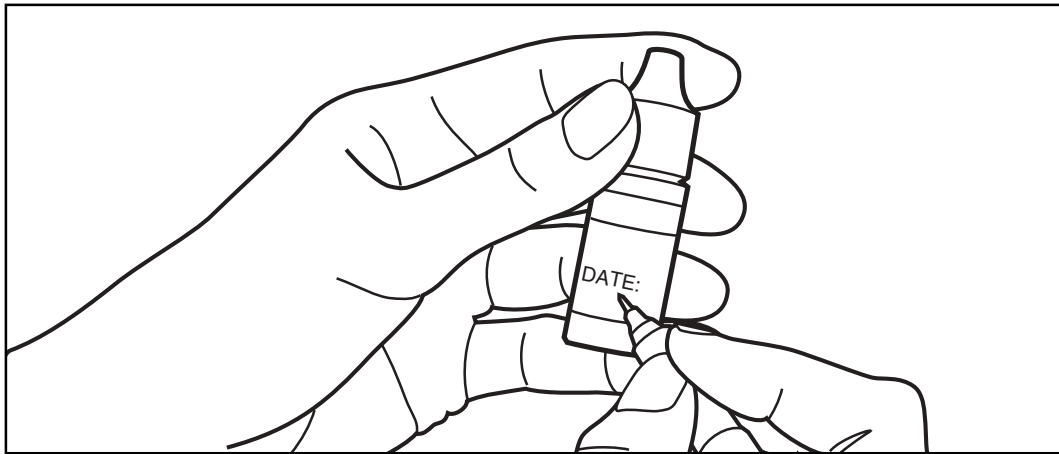

Important: Make sure you use the proper control solution for the test strips you have: Accu-Chek Sensor Comfort Test Strips require Accu-Chek Sensor Comfort Glucose Control Solutions.

Performing a Quality Control Check

1. Open test strip vial and remove test strip.
Replace vial cap.
2. Within 3 minutes, insert test strip (yellow window facing up) into test strip slot. The meter turns on automatically.

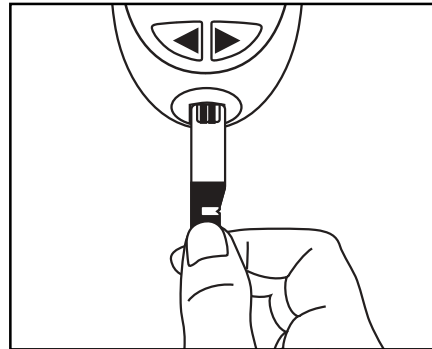

Check that the code number on the meter matches the code on the vial of test strips you are using. The test strip symbol stops flashing and a blood drop symbol appears on the display.

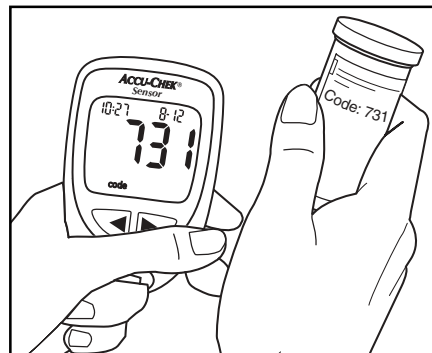

3. Press and release the right arrow button once to select a L1 (Level 1) control or twice to select a L2 (Level 2) control.

Note: Results marked as L1 or L2 do not appear in memory or averages.

4. Hold the control bottle horizontally with the tip pointed directly at the right edge of the strip.

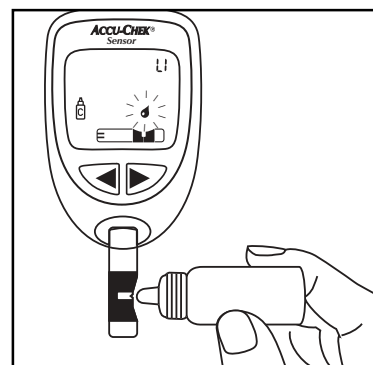

5. Gently squeeze the bottle to form one small drop.
6. Bring the drop to the edge of the strip within the curve, and allow the strip to automatically draw the solution into the yellow window until it is completely filled.

An hourglass flashes in the display until the measurement is complete.

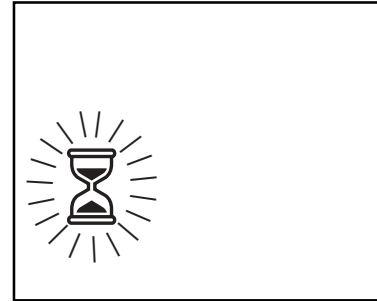

7. Tightly replace the cap on control solution.
8. The control result appears. If result is within the acceptable range (which is found on the side of the vial of strips), an icon of the control vial appears on the screen while the control test result and time and date (if set) alternate with “OK” and “L1” or “L2” on the display.

Example of an acceptable Level 1 control result.

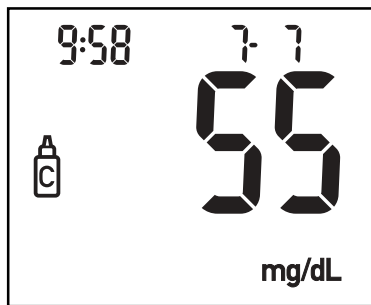

and



or

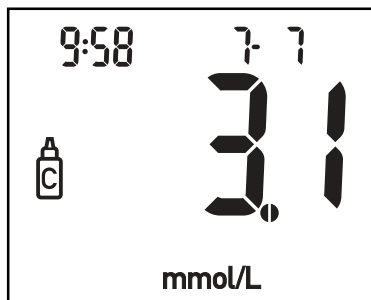

and



Note: Result must be marked with an L1 or L2 for the meter to verify if control result is within range. If result has not been marked with an L1 or L2, refer to your test strip vial label for the glucose control ranges.

If result is not within the acceptable range, an icon of the control vial appears on the screen while the control test result, and time and date (if set), alternate with “Err” and “L1” or “L2” on the display. See **Understanding Control Results** on page 27 for more information.

Example of an unacceptable Level 1 control result.

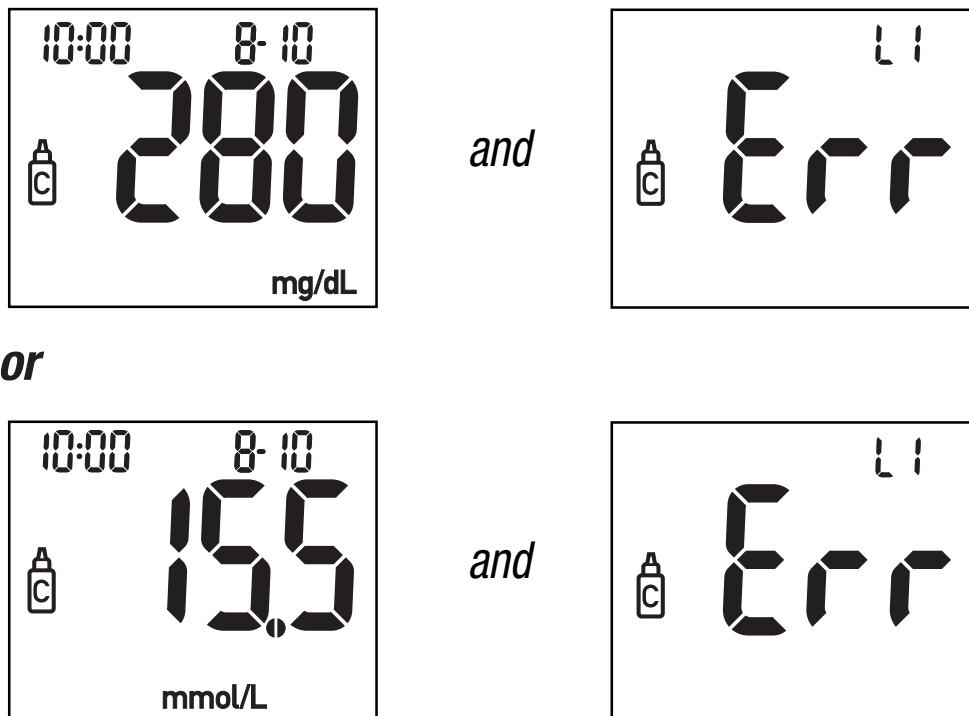

9. Remove test strip from meter and discard.

Note: Marking a test as “L1” or “L2” prevents the quality control result from taking up space in the meter’s memory. If you do not mark the test as a control, the control result is stored in memory and included in averages.

Understanding Control Results

If your glucose control results are within the acceptable range, you can feel confident that your test strips and meter are working correctly.

If one or both of your glucose control results are outside of the acceptable range, your system may not be working properly. Check the following:

- Did you use control solutions or test strips that were past their expiration date?
- Did you leave the cap off the vial of test strips or glucose control solutions?
- Did the code in the meter match the code on the test strip vial label?
- Did you follow the testing steps exactly?
- Did you use the proper glucose control solution for the test strips you used?
- Did you select the appropriate control result level (L1 or L2)?

Repeat the glucose control test. If the result still is not acceptable, contact Roche Diagnostics during business hours.

Caring For Your Meter

Display Check

This verifies that all parts of the display are working. Make sure the meter is off. Press and hold down the ON/OFF button. The display should look exactly like the picture at right. If it does not, call Roche Diagnostics.

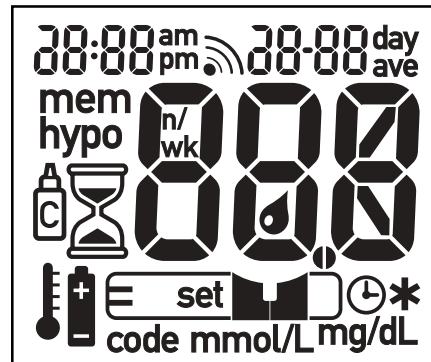

Cleaning

Clean the outside of the meter, as needed, using a soft cloth that has been slightly dampened with one of the following:

- 70% alcohol
- a solution of mild dishwashing liquid and water
- 10% household bleach solution (1 part bleach in 9 parts water) made fresh daily
- Sekupoudre
- Super Sani-wipes (Ammonium Chloride with alcohol)

Do not get moisture into the code key slot, test strip slot, or the serial port.

**⚠ Note to Healthcare Professionals:
Follow the infection control procedures
appropriate for your facility.**

Storage and Handling

Keep your meter free of dust. Protect it from extremes in temperature and humidity, and handle it with care. If meter is dropped, perform a quality control check with the glucose control solutions before doing a blood glucose test.

The travel case is designed to let you store a variety of supplies you may need and helps to protect your meter.

Note to Healthcare Professionals:

Follow the infection control procedures appropriate for your facility. A drop of fresh, whole blood is required to perform a blood glucose test. Fresh venous, capillary, arterial or neonatal blood may be used. Caution should be taken to clear arterial lines before blood is drawn. Caution should be exercised in the interpretation of neonate blood glucose values below 50 mg/dL (2,8 mmol/L). Blood glucose determination with venous or arterial blood must be performed within 30 minutes of sample collection. Iced arterial blood specimens must be tested at room temperature. Avoid air bubbles with the use of pipettes. Fresh venous blood specimens containing the anticoagulants EDTA or heparin are acceptable. Iodoacetate or fluoride/oxalate are not recommended.

Transferring Data

The meter allows you to transfer all the data that you have stored in its memory to your computer so this information can be printed. It allows you to transfer data in two different ways:

- **Directly to your computer using a specialized software and interface cable**
- **Via specialized modems designed for remote transfer**

Consider the following when using accessory equipment:

- **DO NOT run a glucose test when the Accu-Chek Sensor Meter is connected to accessory equipment.**

For more information please contact your doctor or healthcare professional and your local distributor.

Quick Reference Display Guide

Meter needs to be coded/
calibrated, or code key is not
inserted completely; turn meter
OFF and insert code key
(see page 9).

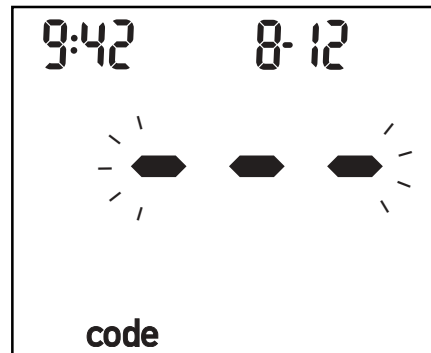

Meter is in the “set” function,
allowing you to set the beeper,
time, date, year, and hypo flag
(see page 4).

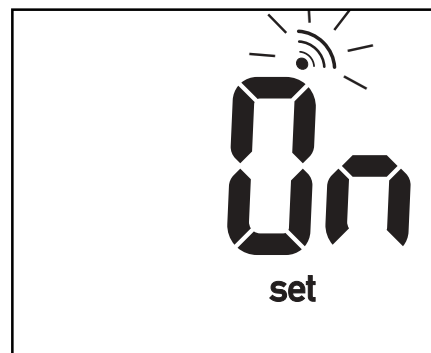

Meter is ready to accept a
test strip.

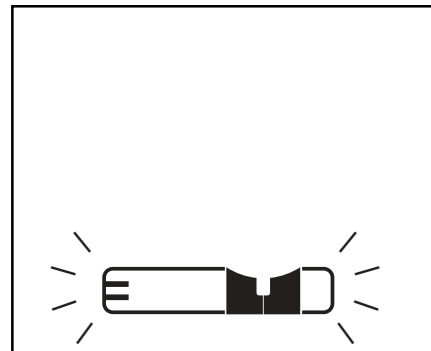

Blood drop can be applied to
test strip (see page 12).

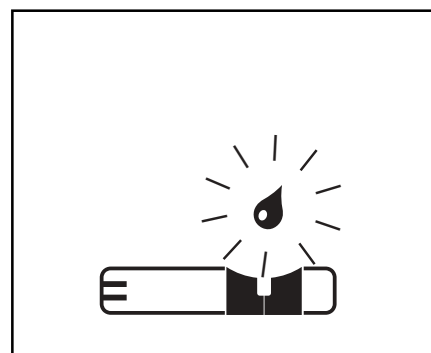

Blood glucose result appears on display (see page 14).

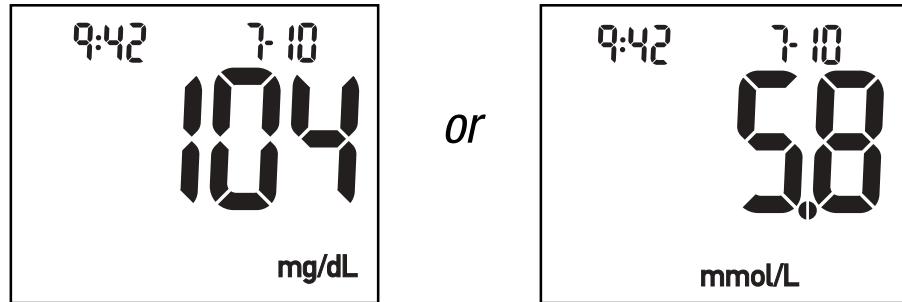

Blood glucose result may be higher than 600 mg/dL (33,3 mmol/L). If this does not confirm the way you feel, review proper testing procedure and perform a quality control check (page 22). Repeat test. **If HI still appears, follow your doctor's instructions.**

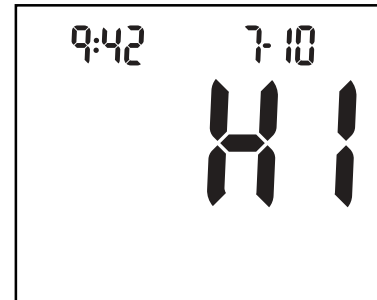

Blood glucose result may be lower than 10 mg/dL (0,6 mmol/L). If this does not confirm the way you feel, review proper testing procedure and perform a quality control check (page 22). Repeat test. **If LO still appears, follow your doctor's instructions.**

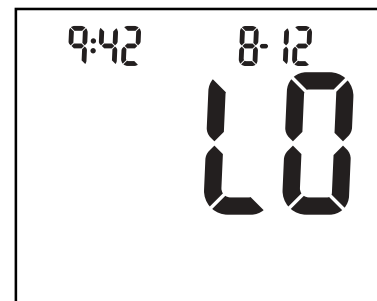

Blood glucose result is lower than hypo flag level set on meter (see page 8).

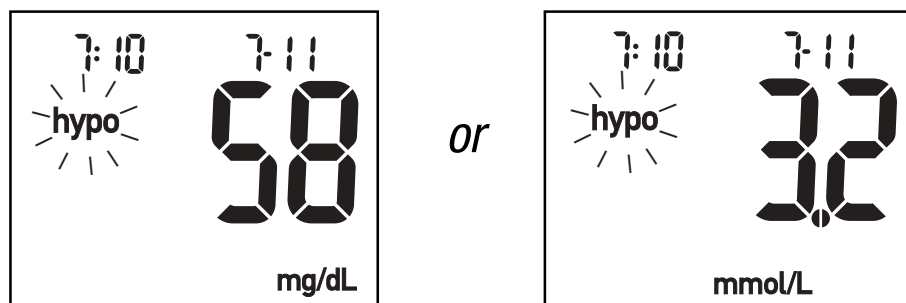

Temperature is above or below the operating range of test strips (14° to 40°C). The result you have obtained may not be accurate. Move to an area between 14° and 40°C, wait 5 minutes, and repeat the test. Do not artificially heat or cool the meter.

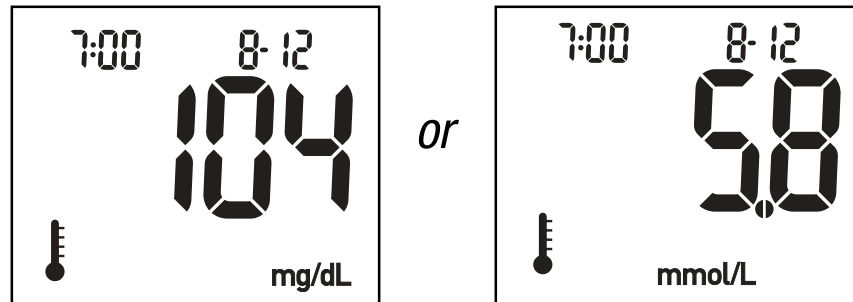

Memory Displays

The meter is in the “memory” function, allowing you to recall results from memory (see page 20).

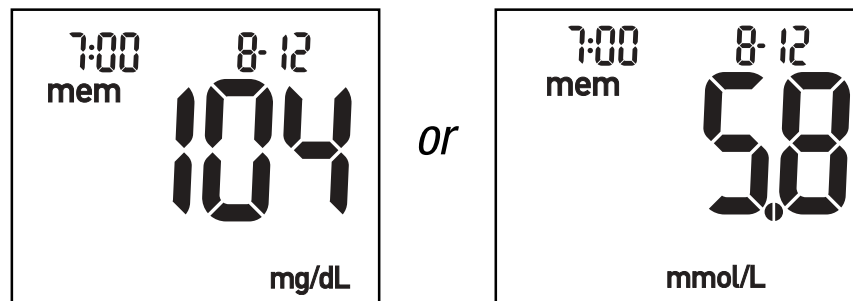

If you are reviewing memory and a result appears with a temperature symbol as shown, this result may not be accurate because the test was performed outside the operating range of the test strips (14° to 40°C).

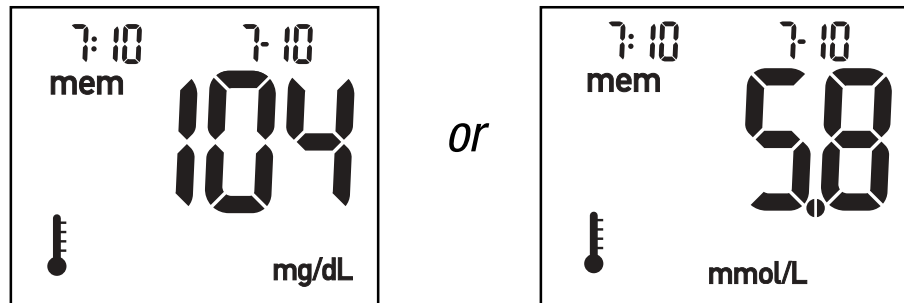

The meter is in the “memory” function, allowing you to recall 7, 14, and 30-day averages.

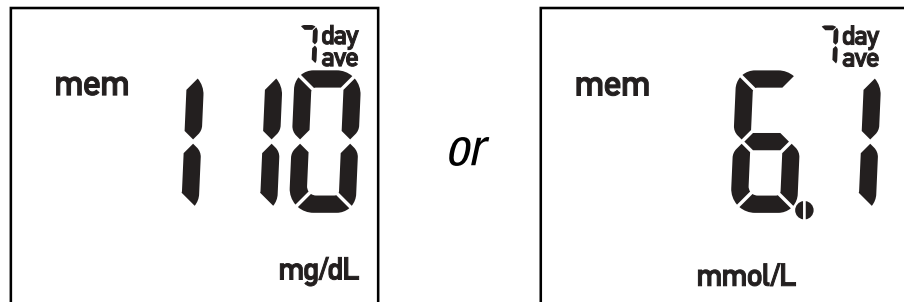

This blood glucose result was marked with a result marker flag (asterisk) (see page 16).

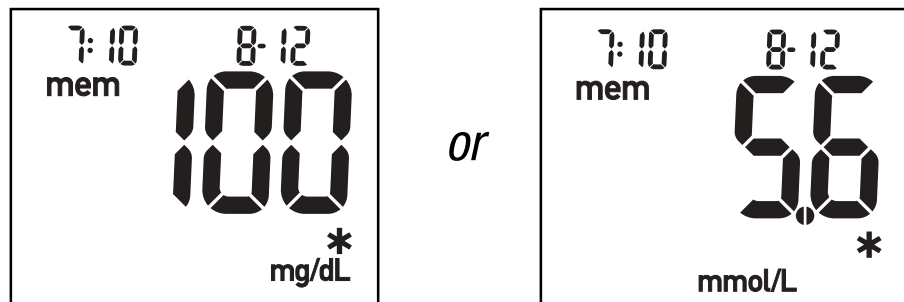

 **Do not use individual values stored in memory to make therapy adjustments.**

Display Messages

Battery Displays

Battery power is low.
Change battery soon.

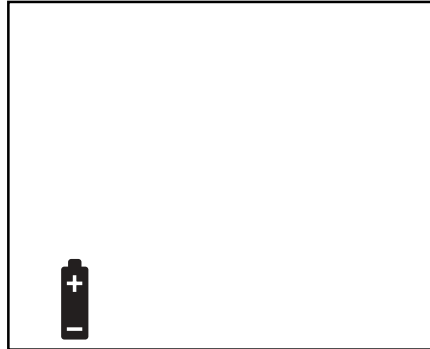

(battery symbol not flashing)

Battery is dead. Change
battery now. Meter will
turn off after 3 seconds.

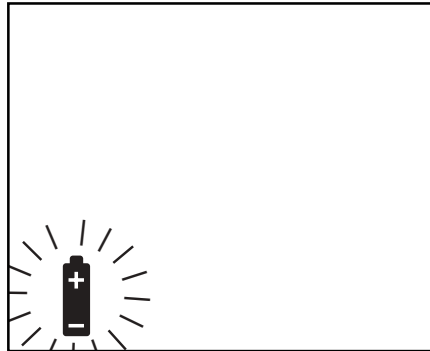

(flashing battery symbol)

Quality Control Check Displays

Meter is ready for a Level 1 or Level 2 glucose control check. Apply a drop of Level 1 or Level 2 glucose control solution.

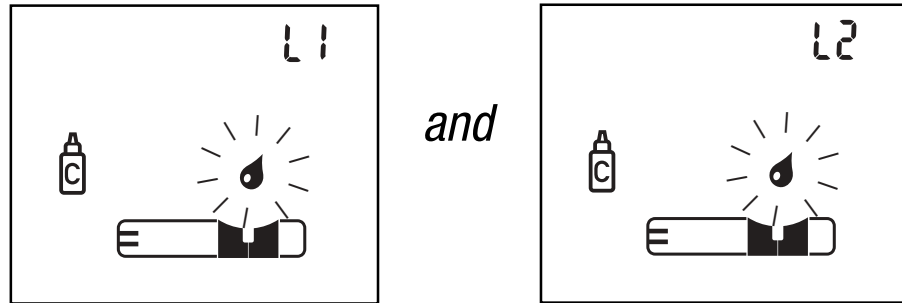

Example of an acceptable control result.

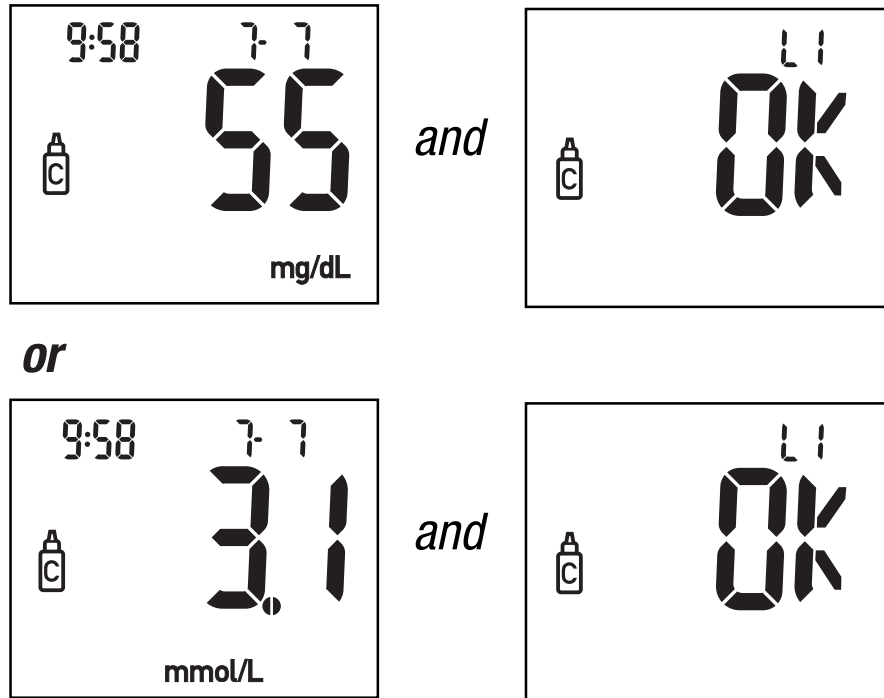

Glucose control result is not acceptable. Repeat test.
Refer to **Understanding Control Results** (see page 27).

Example of an unacceptable control result.

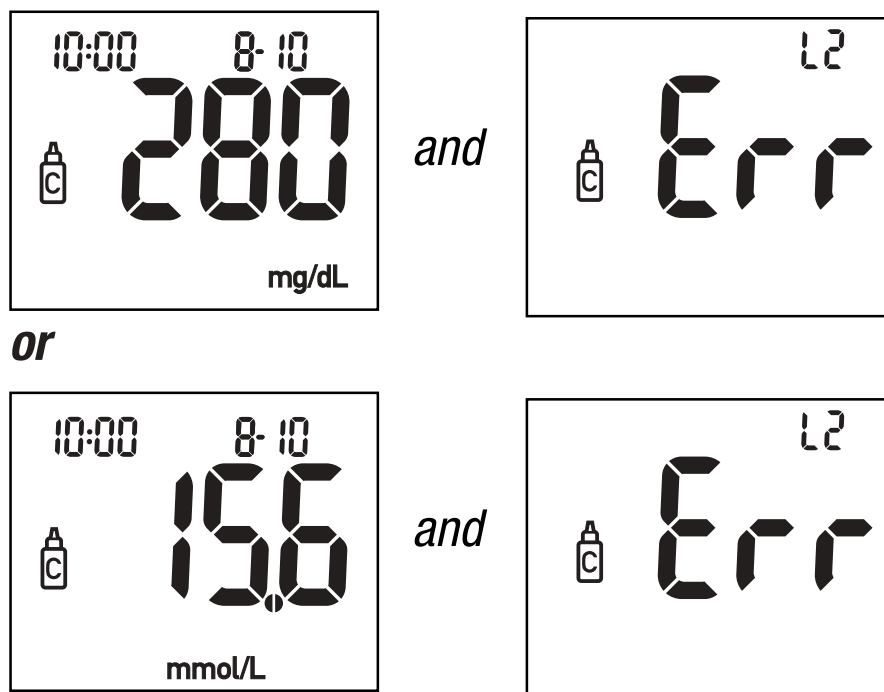

Error Messages

The meter automatically performs a system check to prevent inaccurate results. If the meter detects a malfunction, it displays the “Err” message and an appropriate symbol.

Do not make treatment decisions based on an error message.

The code key is faulty, or the code key was removed while the meter was on. Turn meter OFF and re-insert code key. If this error display still appears, contact Roche Diagnostics.

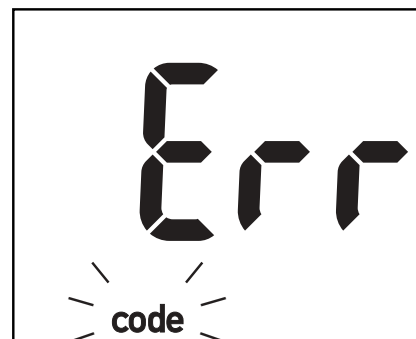

Your blood sugar may be extremely low, an incorrect amount of blood was applied, or the test strip is damaged or inserted improperly. If you see this error message **after** you put blood on the test strip refer to the section in the manual titled ***Understanding Your Test Results*** (see page 17). If you see this error message before you put blood on the strip, remove test strip and reinsert, or insert a new test strip. If the message reappears, call Roche Diagnostics.



Your blood sugar may be extremely high or a meter or strip error has occurred. If this confirms how you feel, contact your healthcare professional immediately. If it does not confirm how you feel, repeat the test and refer to the section in the manual titled ***Understanding Your Test Results*** (see page 17).

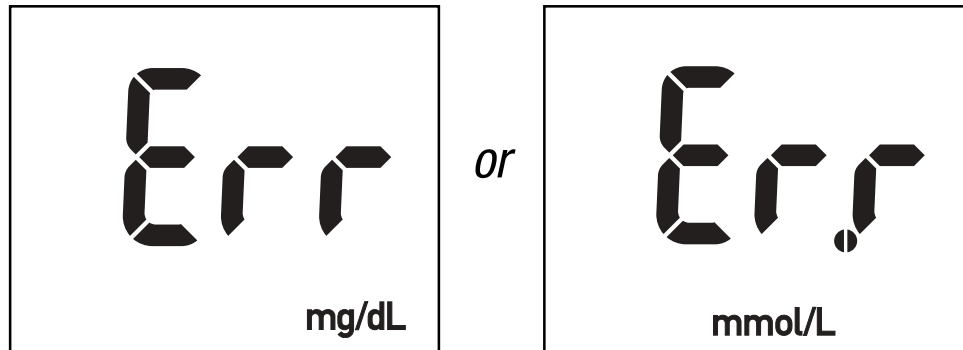

If this does not confirm the way you feel, run a quality control check with your glucose control solutions and a new test strip. If the control result is within the acceptable range, review the proper testing procedure and repeat your blood glucose test with a new test strip.

If **mg/dL error** or **mmol/L error** still appears for your blood glucose test, your blood glucose result may be extremely high or low and above or below the system's reading range. **Contact your doctor immediately.**

If the control result is not within the acceptable range, refer to ***Understanding Control Results*** (see page 27).

Meter has detected the loss of all results in memory. Turn meter OFF and turn it back ON again. You may not be able to recall the results previously stored in memory, although your meter will store any future test results.

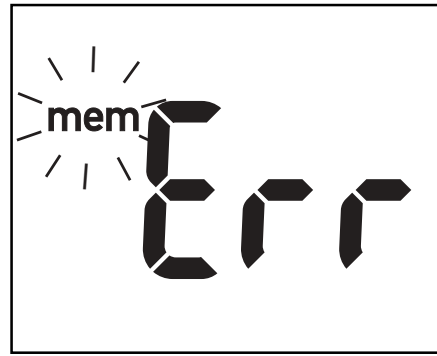

Temperature is above or below the operating range of the meter. Move to an area between 14° and 40°C, wait 5 minutes, and perform a test. Do not artificially heat or cool the meter.

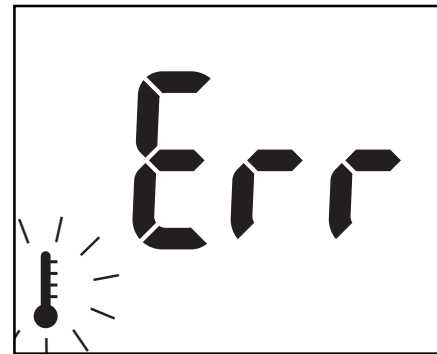

Meter has failed its series of electronic checks. Turn meter OFF, then ON again. If this error display still appears, testing cannot take place. Call Roche Diagnostics.



Technical Data

Please read information packaged with test strips regarding up to date product specifications and limitations.

Measuring Principle: The glucose dehydrogenase converts the glucose in a blood sample to gluconolactone. This reaction liberates an electron that reacts with a coenzyme electron acceptor, the oxidized form of the mediator hexacyanoferrate (III), forming the reduced form of the mediator, hexacyanoferrate (II). The test strip employs the electromechanical principle of biamperometry. The monitor applies a voltage between two identical electrodes, which causes the reduced mediator formed during the incubation period to be reconverted to an oxidized mediator. This generates a small current that is read by the monitor. The meter detects electrical current change and with the aid of the code key, converts the signal obtained into a displayed reading.

Product Specifications

| | |
|-----------------------------|--|
| Meter Storage Conditions | -25° to 70°C <85% humidity ≥53.3 kPa atmospheric pressure |
| System Operating Conditions | Refer to your test strip package insert for more information |
| Measuring Range | Refer to your test strip package insert for more information |
| Memory Capacity | 480 blood glucose results with time and date |
| Display | LCD display |
| Blood Volume | Refer to your test strip package insert for more information |
| Size | 3.3" x 2.2" x .8" (84 mm x 56 mm x 20 mm) |
| Weight | 1.8 oz (57 g) |
| Accuracy | Refer to your test strip package insert for more information |
| Precision | Refer to your test strip package insert for more information |
| Sample Types | Capillary, venous, arterial, and neonatal (including cord) blood |

| | |
|-------------------------------|---|
| Power Supply | One 3-volt lithium battery type 2032 (CR 2032, DL 2032 or equivalent) |
| Data Port | 3-wire RS-232C Serial Port Multiplexed TTL UART |
| Test Strip Storage Conditions | Refer to your test strip package insert for more information |
| Construction | Hand held |
| Protection Class | III |
| Rated Operation | Continuous operation |

Product Safety Information

Explanation of symbols



CAUTION Refer to accompanying documents.



3V type 2032



Laboratory Use
Electrical Equipment
8C79

Listed by Underwriter's
Laboratories, Inc.® in

accordance with UL 61010A-1 and
CAN/CSA C22.2 No. 1010-1.



This product fulfills the requirements of
Directive 98/79 EC on *in vitro* diagnostic
medical devices.



For *in vitro* diagnostic use



Manufactured by

This meter is suitable for continuous operation. Meter is not protected against ingress of water. Meter is not suitable for use in the presence of flammable anesthetic mixture with air, oxygen, or nitrous oxide.

Warranty and Service Instructions

Roche Diagnostics warrants the meter against any material and manufacturing defects that may arise during proper use of the instrument. For precise terms and conditions please see the Warranty Card in the box.

This warranty does not affect any statutory or other rights.

The warranty ceases to apply if the instrument has been misused or tampered with.

Roche undertakes to repair faulty components free of charge or, at their discretion, to provide a fault-free replacement meter.

Be sure to fill out the warranty form that came with your system and return to Roche Diagnostics.

Statutory and other rights: This manufacturer's warranty is in addition to any statutory or other rights which may be acquired by the customer through his dealings with the instrument supplier.

The statutory guarantee provisions governing the sale of consumer goods in the country of purchase shall prevail.

Supplies and Accessories

The following supplies and accessories are available from pharmacies or your local surgical supplier.

Accu-Chek Sensor Comfort Test Strips

Accu-Chek Sensor Comfort Glucose Control Solutions

Accu-Chek Softclix Lancets

Accu-Chek Softclix Lancing Device

Index

| | |
|--|--------------------|
| About your Accu-Chek Sensor Meter | v |
| Accu-Chek Sensor Comfort Test Strip | viii, 11 |
| Batteries | 1, 2, 3 |
| Battery display | 2, 3, 36 |
| Battery life..... | 1 |
| Battery cover | vi, 1 |
| Battery installation | 1 |
| Beeper, turning on or off | 4 |
| Blood sample | 11 |
| Caring for your meter | 28 |
| Cleaning | 28 |
| Checking the system | 22, 24, 27, 28, 39 |
| Checking the display | 28 |
| Code key | vi, 9 |
| Code key slot..... | vi |
| Coding/calibrating your meter..... | 9 |
| Control results..... | 27, 37 |
| Control solutions | 22 |
| Display messages | 36 |
| Display check..... | 28 |
| Do's and don'ts | 18 |

| | |
|---|--------|
| Error messages | 39 |
| Flag (asterisk) | 16 |
| Gathering supplies for testing | 11 |
| Getting a good sample | 11 |
| Glucose control solutions | 22 |
| HI display | 15, 33 |
| Hypo flag | 8 |
| Inserting strip | 12 |
| Level 1 glucose control solution | 24 |
| Level 2 glucose control solution | 24 |
| LO display | 15, 33 |
| Marking a result with a flag, asterisk (*) | 16 |
| Memory | 20 |
| ON/OFF button | v |
| Quality control checks | 22, 37 |
| Quick reference display guide | 32 |
| Recalling stored values | 20 |
| Right and left buttons | v |

| | |
|--|----------------|
| Specifications, product | 43 |
| Storage conditions | 29, 43 |
| Storage and handling | 29 |
| Supplies and accessories | 47 |
| | |
| Testing, blood glucose | 11 |
| Testing, quality control | 22, 27 |
| Test strip slot | v |
| Test strip vial | 10, 12 |
| Time, date, and year setting | 6 |
| Transferring data | 31 |
| Troubleshooting | 17, 22, 27, 39 |
| | |
| Understanding control results | 27 |
| | |
| Warranty | 46 |

Any Questions

We want to give you the help you need for long and reliable service of your meter.

Review your test procedure and make sure that you are performing the steps correctly. If you still have questions, please contact Roche Diagnostics. Please have your Accu-Chek Sensor Meter, Accu-Chek Comfort Test Strips and Accu-Chek Sensor Comfort Glucose Control Solutions available when you call.

IMPORTANT—READ CAREFULLY BEFORE USE.

GUARANTEE: The statutory guarantee provisions governing the sale of consumer goods in the country of purchase shall prevail.

This product may be covered by one or more of the following patents: U.S. Patent Nos. 4,999,632; 4,999,582; 4,963,814; 5,508,171; 5,352,351; 5,405,511; 5,438,271; 5,627,075; 5,288,636; 4,891,319; 5,053,199; 5,366,609; 5,508,171; 5,997,817; 6,254,736; 6,270,637; 4,924,879; Re. 35,803 and Re. 36,268; and Austrian Patent Nos. 0229810 and 0406304. U.S. Patent No. 4,891,319 and Austrian Patent No. 0229810 are licensed from Quadrant Holdings Cambridge Limited.

**© 2003 Roche Diagnostics. All rights reserved.
03654117001-0703**



Roche Diagnostics GmbH
Sandhofer Strasse 116
D-68305 Mannheim, Germany
www.roche.com



ACCU-CHEK and SOFTCLIX are trademarks
of a Member of the Roche Group.

03654117001-0703

2003/06

