

OMRON®

# INSTRUCTION MANUAL



## Automatic Blood Pressure Monitor with Arm Cuff

配備 **Arm Cuff** 臂帶的自動血壓計

Model **IA2**  
型號

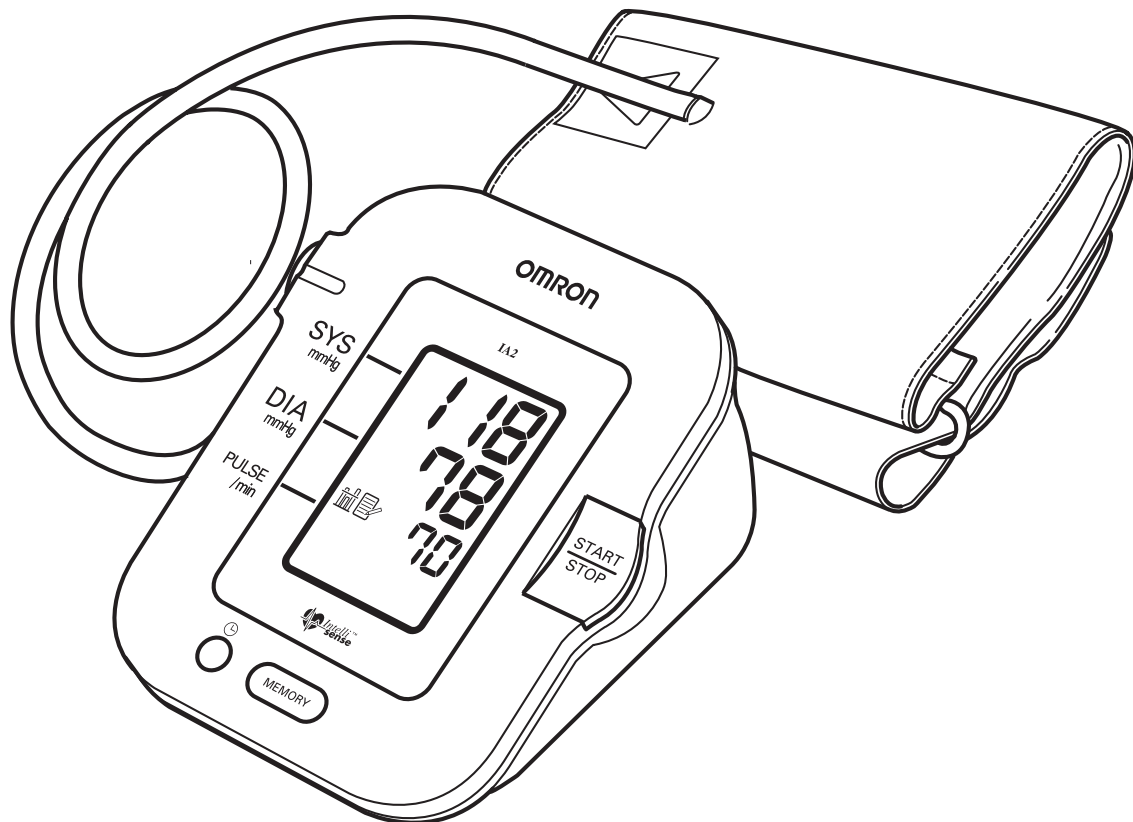

**A Good Sense of Health**

# Contents

<b>Introduction</b>	<b>.2</b>
<b>Notes on Safety</b>	<b>.3</b>
<b>Know Your Unit</b>	<b>.5</b>
<b>Quick Reference Guide</b>	<b>.7</b>
<b>Initial Set-Up</b>	<b>.9</b>
How to Install and Replace Batteries	.9
How to Set the Date and Time	.10
<b>Correct Usage</b>	<b>.13</b>
How to Apply the Arm Cuff	.13
How to Take a Measurement	.16
How to Use the Memory Function	.20
<b>Troubleshooting</b>	<b>.22</b>
<b>Care and Maintenance</b>	<b>.24</b>
<b>Specifications</b>	<b>.25</b>

# Introduction

Thank you for purchasing the IA2 Omron Automatic Blood Pressure Monitor with IntelliSense™. Although your blood pressure fluctuates throughout the day, no self adjustment is necessary as the monitor intelligently adjusts to your changing conditions. The IntelliSense monitor uses fuzzy logic intelligence to sense both your systolic and diastolic blood pressure values, and the result is personalized inflation for every reading. This virtually eliminates discomfort or incorrect readings due to improper cuff inflation.

The IA2 also stores up to 90 sets of measurements in memory and displays an average reading based on the three most recent measurements..

Please read this instruction manual thoroughly before using the unit. For specific information about your own blood pressure, consult your doctor.

# Notes on Safety

- The warning signs and the sample icons shown here are listed in order for you to use the product safely and correctly, as well as to prevent the risk of damage or injury to you and others from happening.
- The icons and meanings are as follows.

Warning Sign	Contents
 <b>Caution</b>	Indicates matters in which bodily harm or material damage* may arise as a result of incorrect handling.

\* Material damage refers to a wide range of damage involving your house, household goods, domestic animals, and pets.

## Examples of Signs





The  icon indicates actions that are prohibited (what you cannot do).

Matters involving prohibited actions are indicated by text or pictures in or near the  icon.



The  icon indicates compulsory actions that must always be followed.

Matters involving compulsory actions are indicated by text or pictures in or near the  icon. The  icon indicates general compulsory items.

## Caution

Self-diagnosis of measured results and treatment are dangerous. Please follow the instructions of your physician.



Do not use the unit on infants or persons who cannot express their consent.

Do not use the unit for any purpose other than measuring blood pressure.

Do not use a cellular phone near the unit. This may result in incorrect operation of the unit.



# Notes on Safety

## Caution

Do not forcibly bend the arm cuff or bend the air tube excessively.

When removing the air tube, pull on the air plug at the connection with the main unit not the tube itself.

Do not apply strong shocks and vibrations to or drop the main unit.

Do not inflate the arm cuff when it is not wrapped around your arm.

When using batteries, the battery liquid may leak and damage the main unit. Please observe the following points.

- When you are not going to use the unit for a long period of time (approximately three months or more), take out the batteries.
- Replace old batteries with new ones immediately.
- Do not use old and new batteries together.
- Do not insert the batteries with their polarities incorrectly aligned.

# Know Your Unit

## Main Unit:

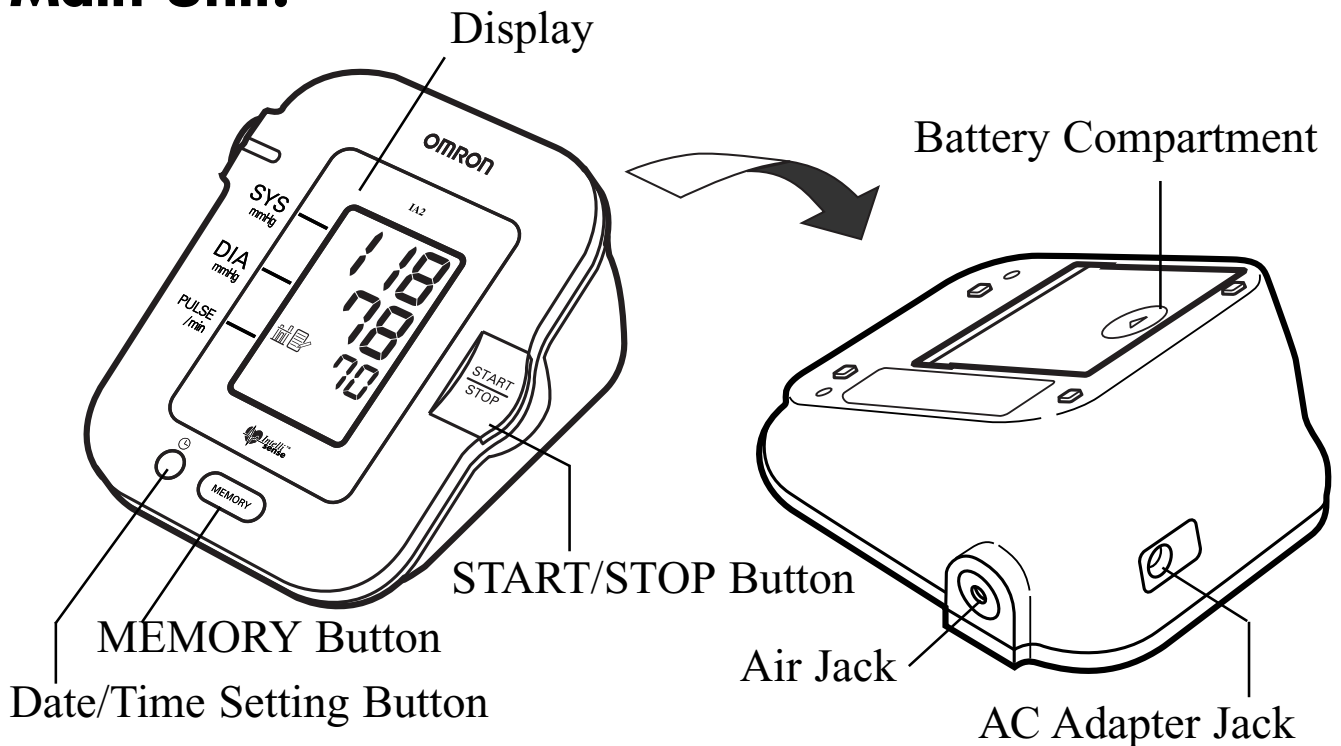

## Display:

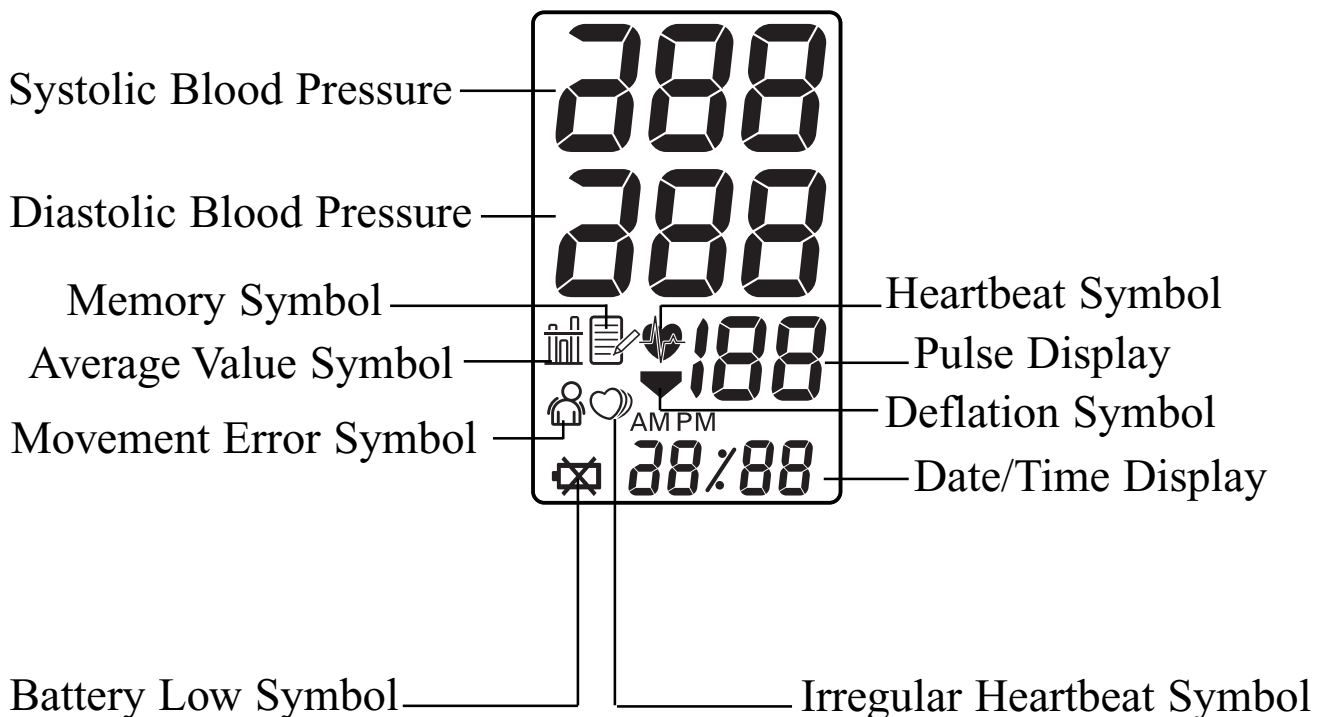

# Know Your Unit

## Accessories:

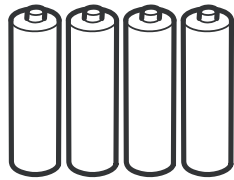
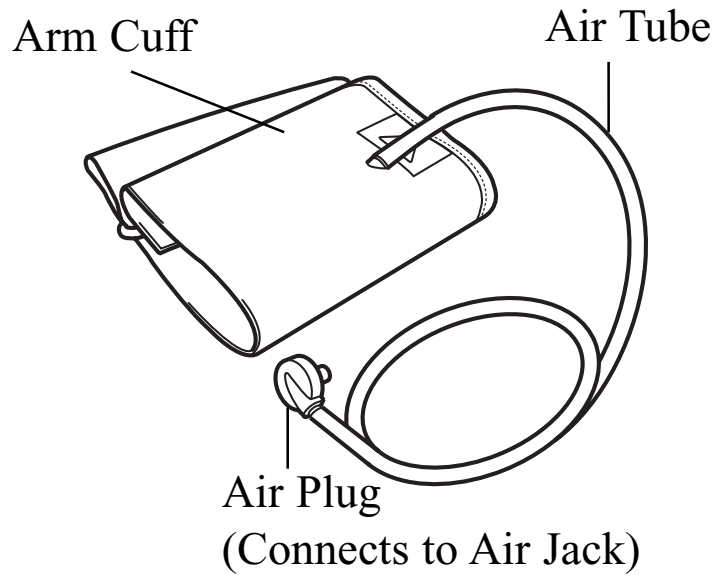

Four "AA" batteries

# Quick Reference Guide

To help ensure a reliable reading, avoid eating, smoking, exercising for at least 30 minutes before taking a measurement. You should also try to measure your blood pressure at the same time each day.

1. Remove any tight-fitting clothing from your upper arm.

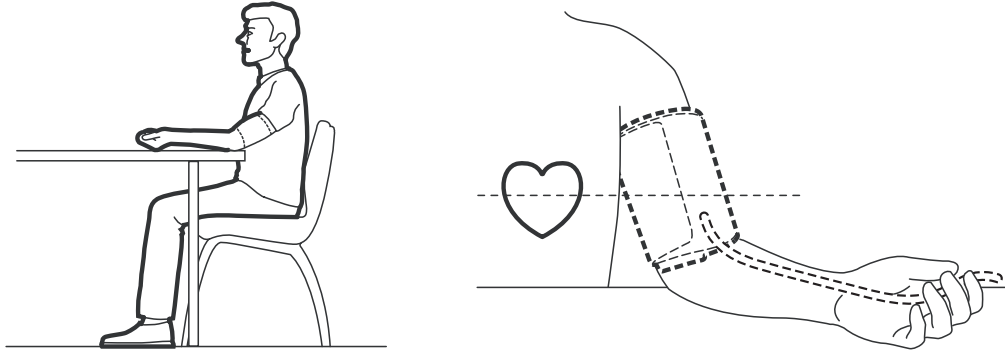

2. Sit on a chair with your feet flat on the floor and place your arm on a table so that the arm cuff will be at the same level as your heart.
3. Apply the arm cuff to your upper arm.

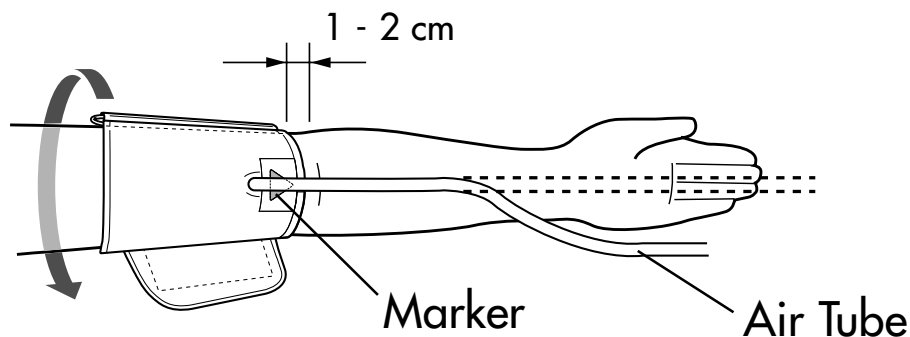

- Apply the arm cuff to your upper arm. The coloured marker should be centered on the inner side of your arm and pointing towards your palm, so that the air tube runs along your forearm and is in line with the middle finger.

4. Secure the cuff around your arm using the velcro strip.



# Quick Reference Guide

5. Press the START/STOP button.

- The arm cuff will start to inflate and the monitor will start the measurement.
- Remain still and do not talk during the measurement.

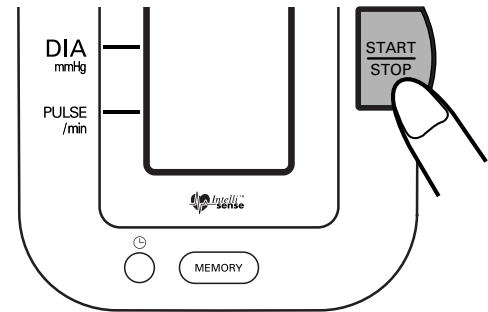

6. When measurement is complete, the monitor displays your blood pressure and pulse rate, and automatically deflates the cuff.



## Notes:

- Always wait at least 2-3 minutes before taking another blood pressure measurement.

**You may require more rest time between readings depending on your individual physiological characteristics.**

- Only use the IA2 to measure your own blood pressure since the results of measurements are stored in memory.

# Initial Set-Up

## How to Install and Replace Batteries

1. Slide the battery cover down and lift it off the main unit.



2. Install or replace four “AA” size batteries so that the + (positive) and - (negative) polarities match the polarities indicated on the battery compartment, then replace the battery cover.

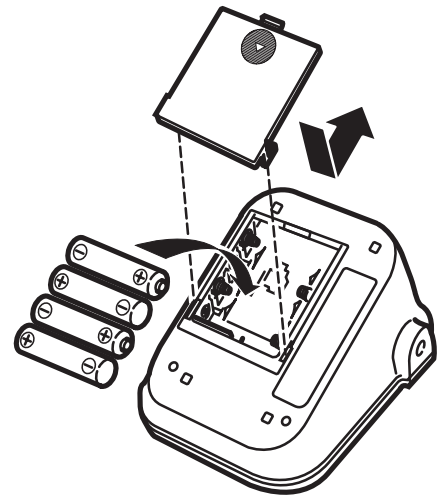

### Notes:

- If the battery low symbol (  ) appears on the display, replace all four batteries at the same time. Long-life alkaline batteries are recommended.
- Remove the batteries if the monitor will not be used for three months or more.
- If the batteries are removed for a long period of time, the Date/Time setting will need to be reset. See “How to Set the Date and Time” for details.
- Dispose of batteries according to applicable local regulations.

# Initial Set-Up

## How to Set the Date and Time

Your blood pressure monitor automatically stores up to 90 measurements values in its memory and calculates an average value based on the last three measurements. To make use of the memory and average values functions, set the monitor to the correct date and time before taking a measurement for the first time.

1. When the batteries are installed for the first time, the year digits (2004) will flash in the display when you turn on the monitor.

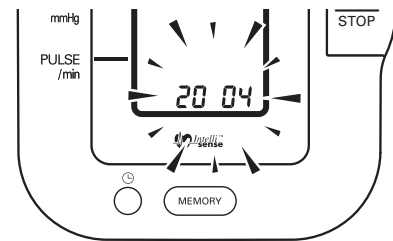

### Notes:

If you need to reset the date and time for some reason, press the Date/Times setting button (⌚) when the monitor is powered off. then the year digit (2004) will flash in the display.

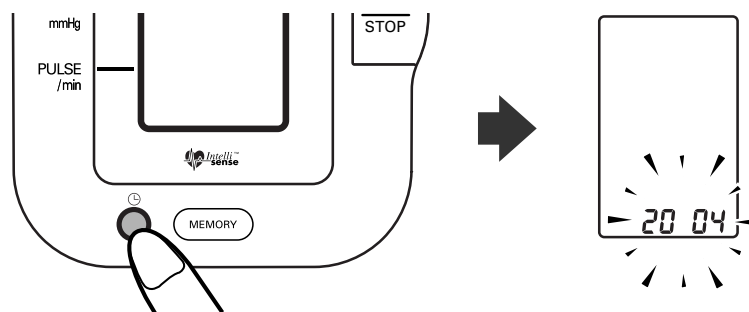

2. Press the MEMORY button to advance the digits one at a time.

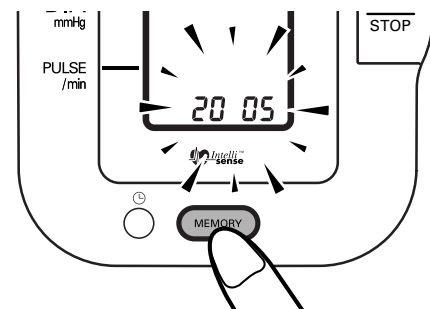

# Initial Set-Up

## Note:

The range for the year setting is 2004 to 2030. If the year reaches 2030, it will return to 2004.

If you hold down the button, the digits will advance rapidly.

3. Press the Date/Time setting button to confirm the setting when the desired number appears on the display.

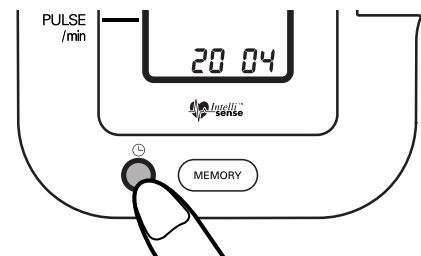

The year setting is set and the month digits will flash.

4. Repeat steps 3 and 4 to set the month and date.

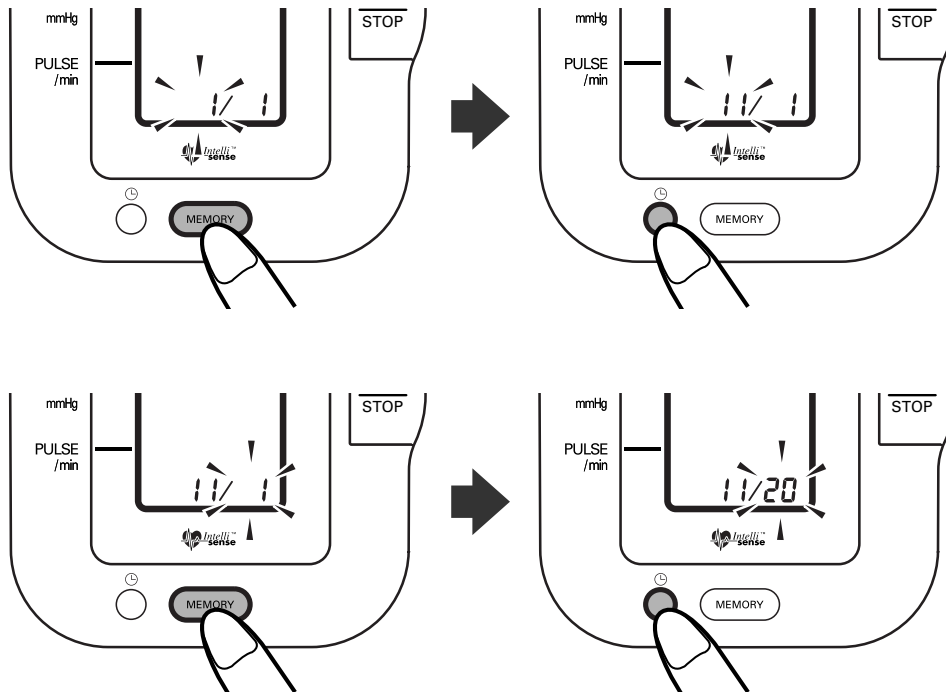

# Initial Set-Up

5. Repeat steps 3 and 4 to set the hour and minutes for the time.

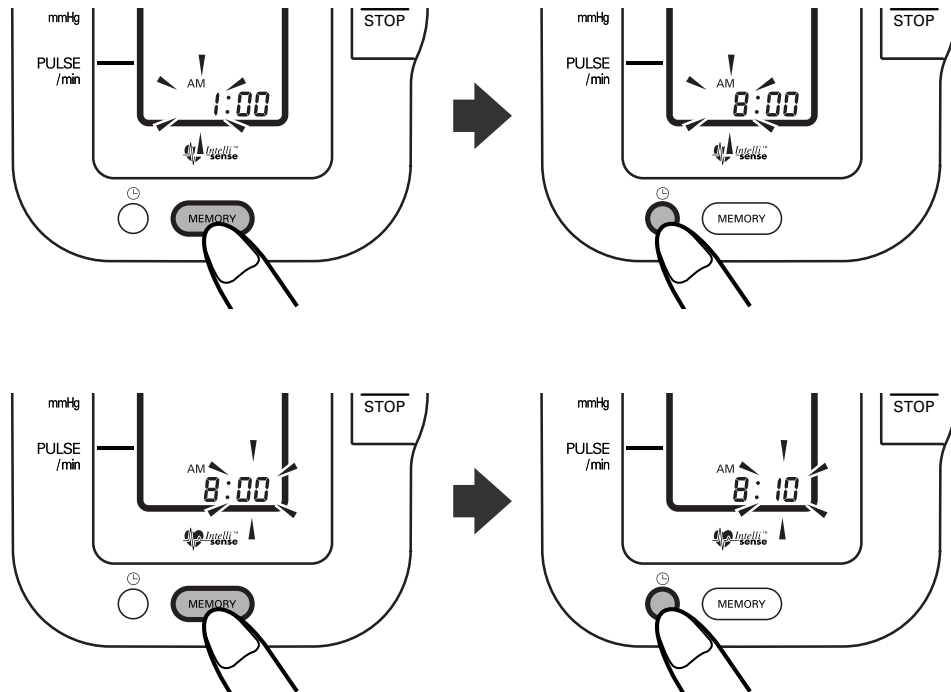

6. The monitor will automatically turn itself off when you press the Date/Time setting button (⌚) after setting the time.

## Note:

If you adjust the date and time during use, press the START/STOP button to turn off the monitor after you have finished adjusting the time.

# Correct Usage

## How to Apply the Arm Cuff

You can wrap the cuff either on your right or left arm.

### Notes:

- Remove tight-fitting clothing from your upper arm.
- Do not place the cuff over thick clothes and do not roll up your sleeve if it is too tight.

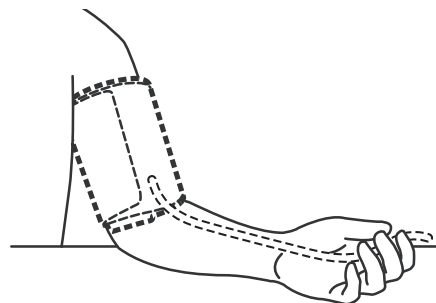

1. If the cuff is assembled correctly, the hook material will be on the outside of the cuff loop and the metal D-ring will not touch your skin.

### Note:

If the cuff is not assembled, pass the end of the cuff furthest from the tubing through the metal D-ring to form a loop. The smooth cloth should be on the inside of the cuff loop.

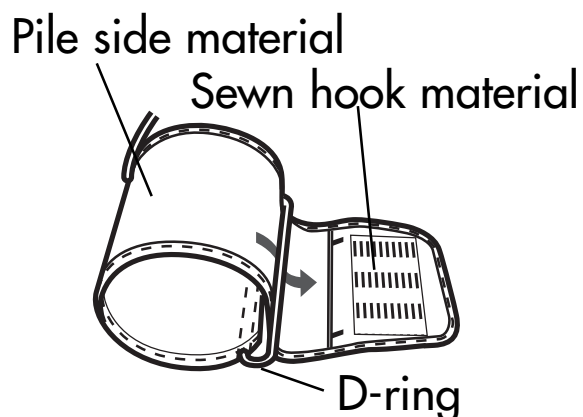

2. Insert the air plug into the air jack (on the left side of the device).

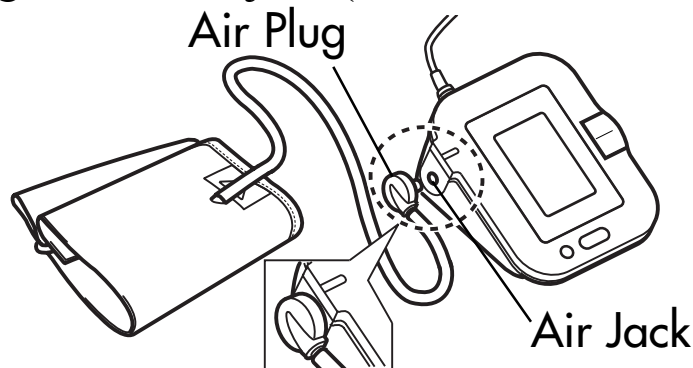

# Correct Usage

The cuff must be fully deflated when the air plug is inserted into the air jack.

3. Sit in a chair with your feet flat on the floor and place your arm on a table so that the cuff will be at the same level as your heart.

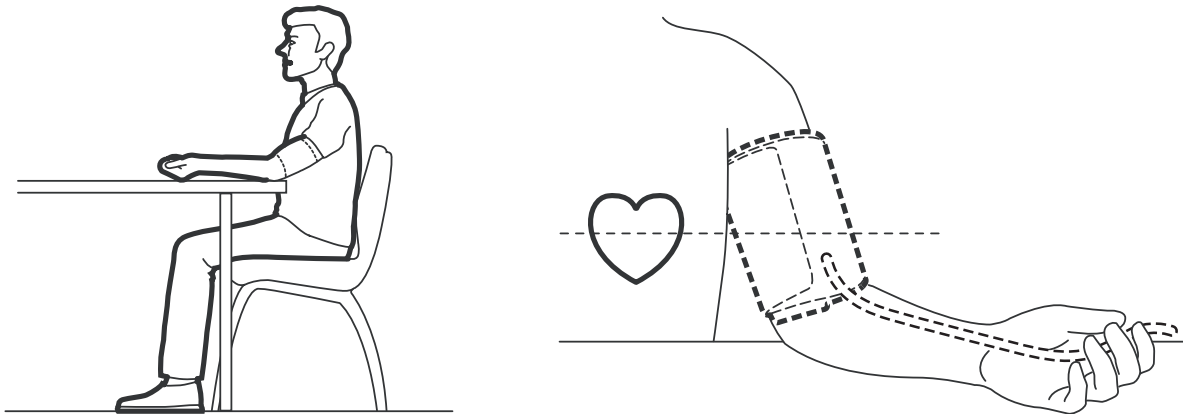

4. Put your arm through the cuff loop.

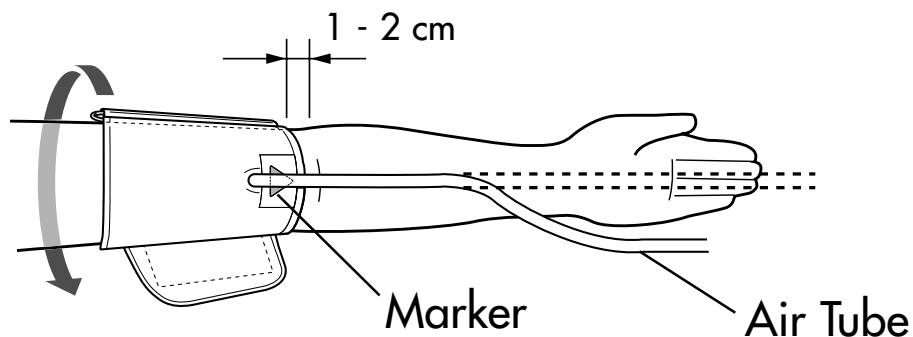

The bottom of the cuff should be approximately 1 - 2 cm above the elbow.

Apply the cuff to your upper arm so that the colored marker is centered on the middle of your inner arm and points towards your middle finger. The air tube should run down your forearm and be in line with the middle finger.

# Correct Usage

5. Pull the cuff so that the top and bottom edges are tightened evenly around your arm.

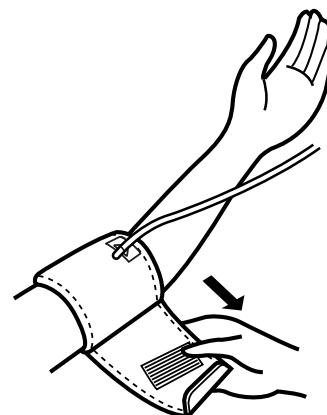

6. When the cuff is positioned correctly, close the fabric fastener FIRMLY.

## Notes:

- Make certain the cuff fits snugly around your arm.
- The cuff should make good contact with your skin. You should be able to fit your index finger between the cuff and your arm easily, so you can pull the cuff off and on.
- Make sure that there are no kinks in the air tubing.

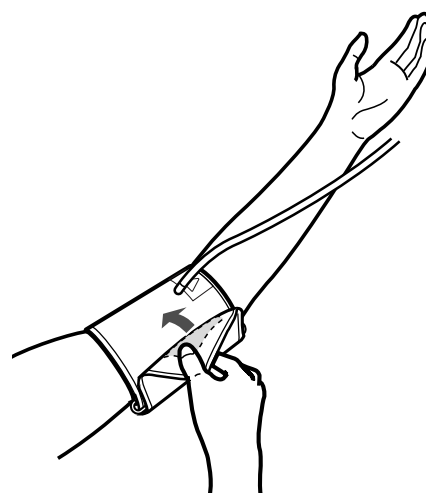

## ***Taking measurements on the right arm***

Please note the following points when applying the cuff to your right arm. Apply the cuff so that the air tube is at the side of your elbow.

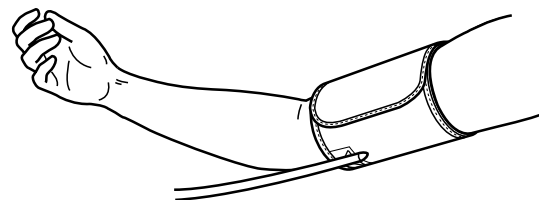

## Notes:

- Be careful not to rest your arm on the air tube, otherwise it will restrict the flow of air to the cuff.
- Apply the arm cuff so that no part of the cuff is positioned over the elbow joint. The cuff should be 1 - 2 cm above the elbow.



# Correct Usage

## How to Take a Measurement

1. Press the START/STOP button and remain still, the cuff will start to inflate automatically.

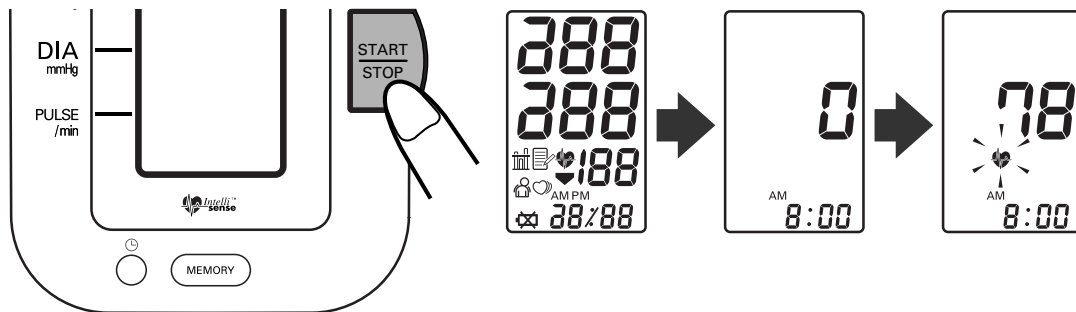



As the cuff begins to inflate, the monitor automatically determines your ideal inflation level. Because this monitor detects the pulse even during inflation, do not move your arm and remain still until the entire measurement process has been completed.

### Note:

Do not inflate the cuff if it is not wrapped around your arm.

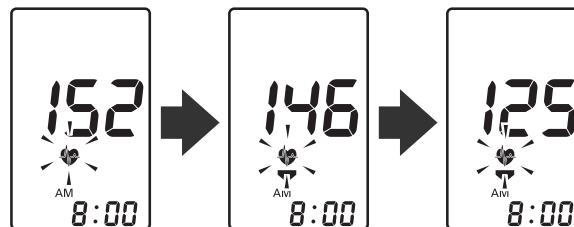
2. Inflation stops automatically and measurement is started.



As the cuff slowly deflates, decreasing numbers appear on the display and the Heartbeat Symbol (  ) flashes at every heartbeat.

In rare circumstances, a higher inflation may be necessary. In these cases, the monitor automatically reinflates the cuff up to 40 mmHg higher than the initial inflation and restarts the measurement.

# Correct Usage

3. When the measurement is complete, the arm cuff completely deflates and your blood pressure and pulse rate are displayed.

**Note:**

The monitor automatically stores blood pressure and pulse rate into its memory.



4. Press the START/STOP button to turn the monitor off.

**Note:**

If you forget to turn the monitor off, it will automatically shut itself off after five minutes.

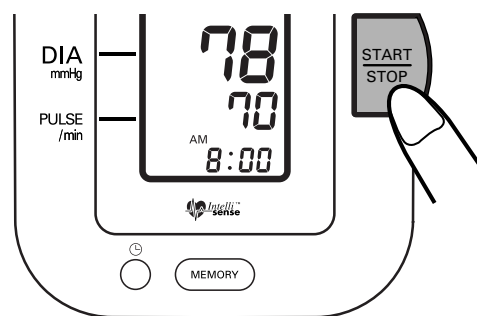

**Important:**

- **Wait 2-3 minutes before taking another blood pressure measurement. Waiting between readings allows the arteries to return to the condition prior to taking the blood pressure measurement.**
- **If you move during measurement, the movement error symbol (⚠) may appear. Repeat the measurement and remain still until the measurement is complete.**

# Correct Usage

- **Your blood pressure monitor includes an irregular heartbeat feature. Irregular heartbeats can influence the results of the measurement. The irregular heartbeat feature automatically determines if the measurement is usable or needs to be repeated. If the measurement results are affected by irregular heartbeats but the result is valid, the result is shown together with the irregular heartbeat symbol (♡). If the irregular heartbeats cause the measurement to be invalid, no result is shown. If the irregular heartbeat symbol (♡) is shown after you have taken a measurement, repeat the measurement. If the irregular heartbeat symbol (♡) is shown frequently, please let your doctor be aware of it.**

## ***Instructions for special conditions***

If your systolic pressure is known to be more than 220 mmHg, press and hold the START/STOP button until the monitor inflates 30 to 40 mmHg higher than your suspected systolic pressure.

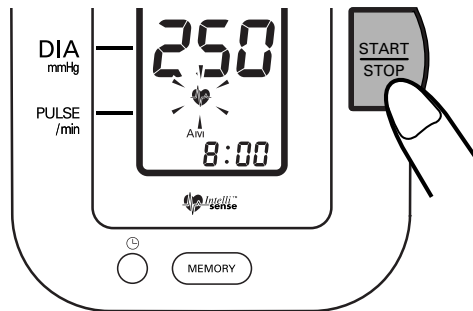

## **Notes:**

- The monitor will not inflate above 299 mmHg.
- Do not apply more pressure than necessary.

# Correct Usage

## What is Irregular Heartbeat?

An irregular heartbeat is a heartbeat rhythm that varies by more than 25% from the average heartbeat rhythm detected while the unit is measuring the systolic and diastolic blood pressure.

If such an irregular rhythm is detected more than twice during measurement, the irregular

heartbeat symbol (🫶) appears on the display when the measurement results are displayed.

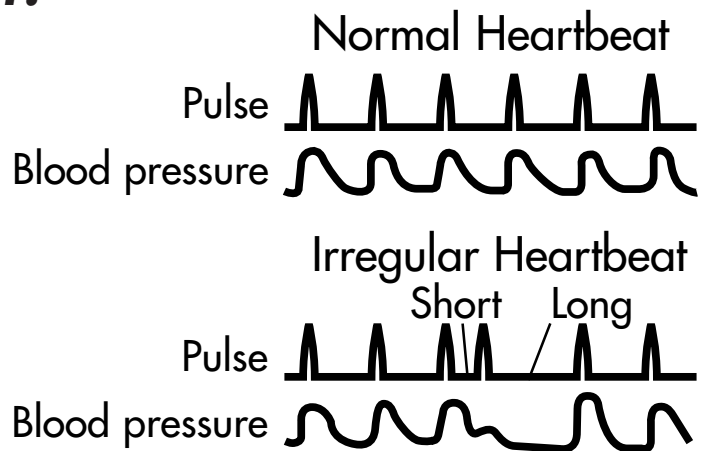

## What is Arrhythmia?

A heartbeat is stimulated by electrical signals that cause the heart to contract.

Arrhythmia is a condition where the heartbeat rhythm is abnormal due to flaws in the bio-electrical system that drives the heartbeat. Typical symptoms are skipped heartbeats, premature contraction, an abnormally rapid (tachycardia) or slow (bradycardia) pulse. This can be caused by heart disease, aging, physical predisposition, stress, lack of sleep, fatigue etc. Arrhythmia can only be diagnosed by a doctor through a special examination.

Whether the appearance of the irregular heartbeat symbol (🫶) in the results indicates arrhythmia or not can only be determined by an examination and diagnosis by your doctor.

If the irregular heartbeat symbol (🫶) is shown frequently, please let your doctor be aware of it. Self-diagnosis and treatment based on measurement results is dangerous. Be sure to follow the instructions of your doctor.

# Correct Usage

## How to Use the Memory Function

This monitor has a memory capable of storing 90 sets of readings. Every time you complete the measurement, the monitor automatically stores the blood pressure and pulse rate. The monitor also calculates an average reading based on the measurements from the last three readings.

To ensure that the measurement results are recorded correctly, make sure that the date and time are set correctly before taking a measurement.

When 90 sets of readings are stored in memory, the oldest set will be deleted to store a new set.

The date and time of stored readings will be alternately displayed.

## To View the Average Value

Press the MEMORY button.

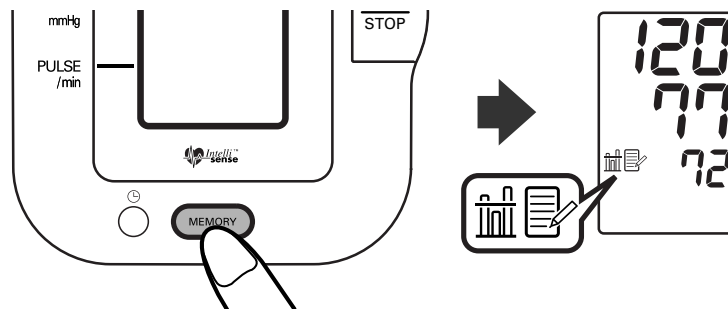

The average values based on the three most recent measurements is displayed.

# Correct Usage

## To View Previous Measurement Values

Press the MEMORY button to view the values from previous measurements. The date and time of each measurement is displayed along with the measurement values.

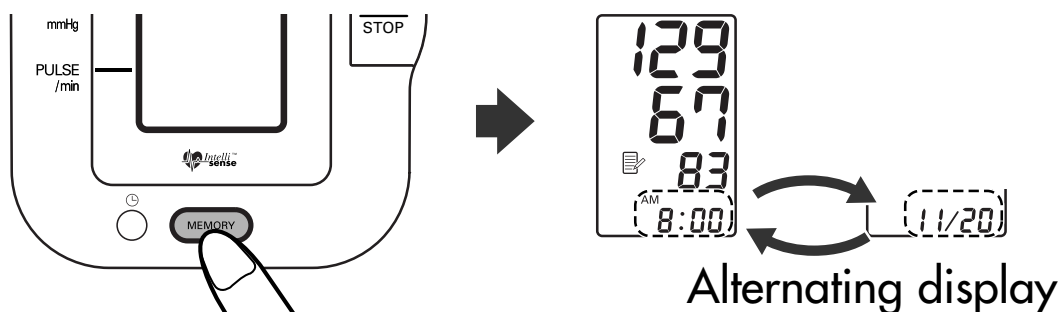

Press the MEMORY button repeatedly to cycle through the previous measurement values

Keep the button pressed down to cycle rapidly through the previous values.

## To Delete All the Values Stored in Memory



### Caution:

**You cannot delete the stored readings partially, all the reading in the monitor will be deleted.**

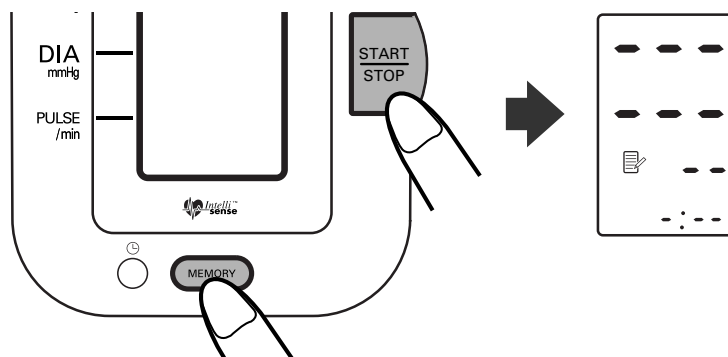
To delete stored readings, press the MEMORY button and the START/STOP button simultaneously, all the readings will be deleted.

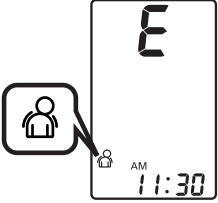

# Troubleshooting

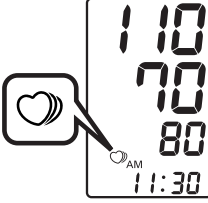
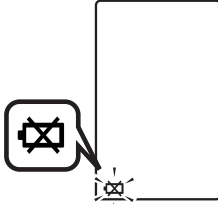
Error Symbol	Cause	Correction
	Cuff is under inflated.	Carefully read and repeat the steps listed under “How to Take a Measurement” on p. 16.
	Movement during measurement.	
	Cuff over inflated.	
	This icon indicates irregular or weak pulses are detected, but the result can be considered reliable.	Remove the arm cuff. Wait 2-3 minutes and then take another measurement. Repeat the steps listed under “How to Take a Measurement” on p. 16. If this error continues to appear, consult your doctor.
	Batteries have run down.	Replace all four “AA” batteries with new ones.

# Troubleshooting

<b>Problem</b>	<b>Cause</b>	<b>Remedy</b>
No display appears when the START/STOP button is pressed.	The batteries are flat.	Replace the batteries.
Cannot measure or readings are too high.	Is the cuff wrapped firmly around the arm?	Attach the arm cuff correctly.
The blood pressure is different each time. The reading is extremely low (or high).	Blood pressure readings constantly vary with time of measurement and nervous condition. Take deep breaths to relax before taking a measurement.	



# Care and Maintenance

Keep the monitor in its storage case when not in use.

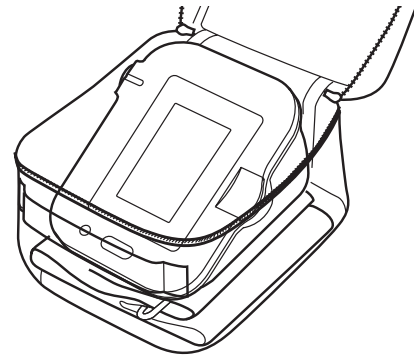

To protect your monitor from damage, please observe the following:

- Do not subject your monitor and cuff to extreme temperatures, humidity, moisture or direct sunlight.
- Do not fold the cuff or tubing tightly.
- Do not inflate the monitor over 299 mmHg.
- Do not disassemble the monitor.
- Do not subject the monitor to strong shocks or vibrations (for example, dropping the monitor on the floor).
- Do not use volatile liquids to clean the monitor. **THE MONITOR SHOULD BE CLEANED WITH A SOFT, DRY CLOTH.**
- Do not wash the arm cuff or immerse it in water.

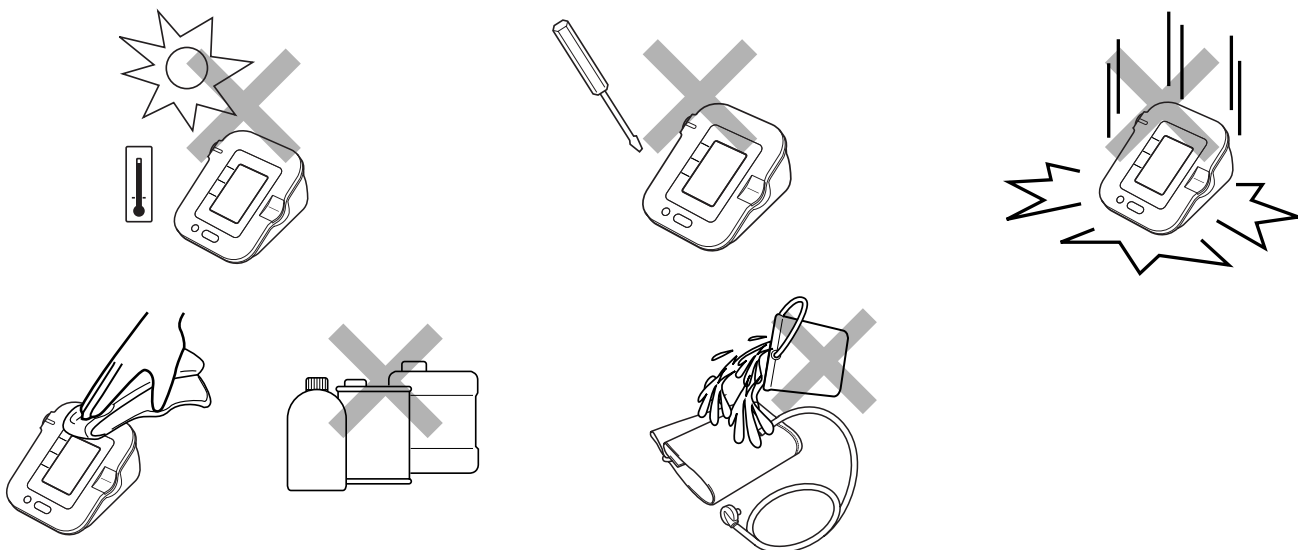

# Specifications

Model:	IA2
Display:	LCD Digital Display
Measurement Range:	Pressure: 0 to 299 mmHg, Pulse: 40-180 beats/min.
Memory:	90 measurements with date and time
Accuracy/Calibration:	Pressure: $\pm 3$ mmHg or 2% of reading Pulse: $\pm 5$ % of reading
Inflation:	Automatic by electric pump
Deflation:	Automatic pressure release valve
Rapid Air Release:	Automatic exhaust valve
Pressure Detection:	Capacitive pressure sensor
Measurement Method:	Oscillometric method
Pulse Wave Detection:	Capacitance type pressure sensor
Power Source:	4 "AA" batteries
Battery Life:	Approx. 300 uses when used once a day for 2 minutes
Operating Temperature /Humidity:	10°C to 40°C / 30 to 85% RH
Storage Temperature /Humidity:	-20°C to 60°C / 10 to 95% RH
Main Unit Weight:	Approximately 355 g not including Arm Cuff and Batteries
Main Unit Dimensions:	Approx. 155 mm (l) x 84 mm (w) x 131 mm (h)
Cuff Size:	Approximately 140 mm (w) x 480 mm (l) Cuff tube 600 mm (l)
Cuff Circumference:	Fits arm circumferences 220mm to 320mm
Contents:	Main Unit, Arm Cuff, Four "AA" Batteries, Instruction Manual, and Storage Case

**NOTE: These specifications are subject to change without notice.**