

Europe / Middle-East / Africa

■ Microlife AG
Esenstrasse 139
9443 Widnau / Switzerland
Tel. +41 / 71 727 70 30
Fax +41 / 71 727 70 39
Email admin@microlife.ch
www.microlife.com

Asia

Microlife Corporation.
9F, 431, RuiGang Road, NeiHu
Taipei, 11492, Taiwan, R.O.C.
Tel. 886 2 8797-1288
Fax 886 2 8797-1283
Email service@microlife.com.tw
www.microlife.com

North / Central / South America

Microlife USA, Inc.
1617 Gulf to Bay Blvd., 2nd Floor Ste A
Clearwater, FL 33755 / USA
Tel. +1 727 442 5353
Fax +1 727 442 5377
Email msa@microlifeusa.com
www.microlife.com

C€0044

IB BP 3AG1-30&W EN-SR 2914



Microlife BP 3AG1

EN → 1
SR → 6



microlife[®]

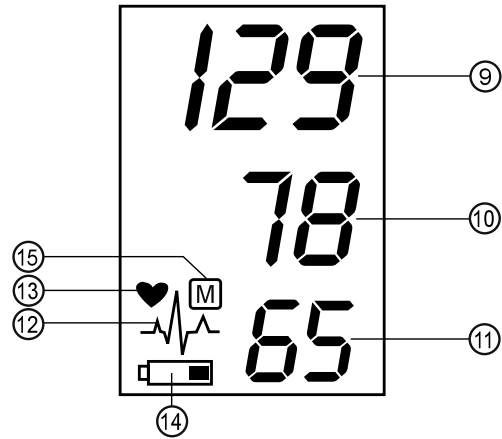
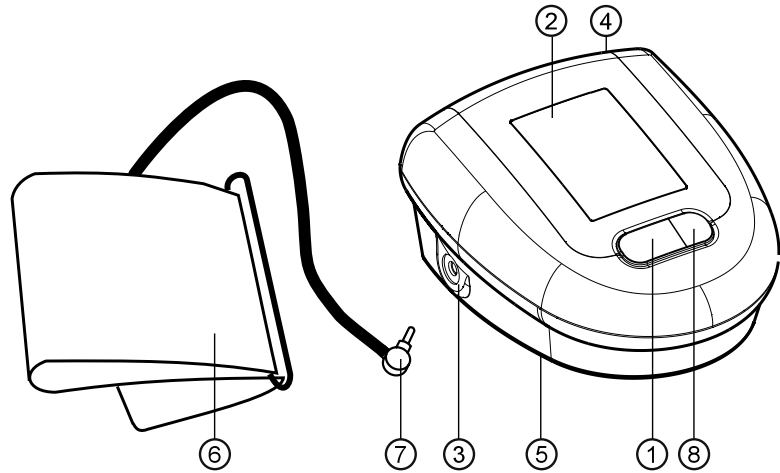

Name of Purchaser
Ime i prezime kupca

Serial Number
Serijski broj

Date of Purchase
Datum kupovine

Specialist Dealer
Ovlašćeni diler

- ① ON/OFF button
- ② Display
- ③ Cuff Socket
- ④ Mains Adapter Socket
- ⑤ Battery Compartment
- ⑥ Cuff
- ⑦ Cuff Connector
- ⑧ M-button (memory)

Display

- ⑨ Systolic Value
- ⑩ Diastolic Value
- ⑪ Pulse Rate
- ⑫ Heart Arrhythmia Indicator
- ⑬ Pulse
- ⑭ Battery Display
- ⑮ Stored Value

 Read the instructions carefully before using this device.

 Type BF applied part

Dear Customer,
Your new Microlife blood pressure monitor is a reliable medical device for taking measurements on the upper arm. It is simple to use, accurate and comes highly recommended for blood pressure monitoring in your home. This device was developed in collaboration with physicians and clinical tests carried out prove its measurement accuracy to be of a very high standard.* Please read through these instructions carefully so that you understand all functions and safety information. We want you to be happy with your Microlife product. If you have any questions, problems or want to order spare parts please contact your local Microlife-Customer Service. Your dealer or pharmacy will be able to give you the address of the Microlife dealer in your country. Alternatively, visit the internet at www.microlife.com where you will find a wealth of invaluable information on our products. Stay healthy – Microlife AG!

** This device uses the same measuring technology as the award winning «BP 3BTO-A» model tested according to the British Hypertension Society (BHS) protocol.*

Table of Contents

- 1. Important Facts about Blood Pressure and Self-Measurement**
 - How do I evaluate my blood pressure?
- 2. Using the device for the First Time**
 - Inserting the batteries
 - Selecting the correct cuff
- 3. Taking a Blood Pressure Measurement using this device**
- 4. Appearance of the Heart Arrhythmia Indicator for early Detection**
- 5. Data Memory**
 - Viewing the stored values
 - Memory full
 - Clearing all values
 - How not to store a reading
- 6. Battery Indicator and Battery change**
 - Low battery
 - Flat battery – replacement
 - Which batteries and which procedure?
 - Using rechargeable batteries

- 7. Using a Mains Adapter
- 8. Error Messages
- 9. Safety, Care, Accuracy Test and Disposal
 - Safety and protection
 - Device care
 - Cleaning the cuff
 - Accuracy test
 - Disposal
- 10. Guarantee
- 11. Technical Specifications
 - Guarantee Card (see Back Cover)

1. Important Facts about Blood Pressure and Self-Measurement

- **Blood pressure** is the pressure of the blood flowing in the arteries generated by the pumping of the heart. Two values, the **systolic** (upper) value and the **diastolic** (lower) value, are always measured.
- The device indicates the **pulse rate** (the number of times the heart beats in a minute).
- **Permanently high blood pressure values can damage your health and must be treated by your doctor!**
- Always discuss your values with your doctor and tell him/her if you have noticed anything unusual or feel unsure. **Never rely on single blood pressure readings.**
- Enter your readings in the enclosed **blood pressure diary**. This will give your doctor a quick overview.
- There are many causes of excessively **high blood pressure values**. Your doctor will explain them in more detail and offer treatment where appropriate. Besides medication, relaxation techniques, weight loss and exercise can also lower your blood pressure.
- **Under no circumstances should you alter the dosages of any drugs prescribed by your doctor!**
- Depending on physical exertion and condition, blood pressure is subject to wide fluctuations as the day progresses. **You should therefore take your measurements in the same quiet conditions and when you feel relaxed!** Take at least two measurements per day, one in the morning and one in the evening.
- It is quite normal for two measurements taken in quick succession to produce significantly **different results**.

- **Deviations** between measurements taken by your doctor or in the pharmacy and those taken at home are quite normal, as these situations are completely different.
- **Several measurements** provide a much clearer picture than just one single measurement.
- **Leave a small break** of at least 15 seconds between two measurements.
- If you are **pregnant**, you should monitor your blood pressure very closely as it can change drastically during this time!
- If you suffer from an **irregular heartbeat** (arrhythmia, see «Section 4.»), measurements taken with this device should only be evaluated after consultation with your doctor.
- **The pulse display is not suitable for checking the frequency of heart pacemakers!**

How do I evaluate my blood pressure?

Table for classifying blood pressure values in adults in accordance with the World Health Organisation (WHO) in 2003. Data in mmHg.

| Range | Systolic | Diastolic | Recommendation |
|------------------------------------|-----------|-----------|-------------------------------|
| blood pressure too low | ↓ 100 | ↓ 60 | Consult your doctor |
| 1. blood pressure optimum | 100 - 120 | 60 - 80 | Self-check |
| 2. blood pressure normal | 120 - 130 | 80 - 85 | Self-check |
| 3. blood pressure slightly high | 130 - 140 | 85 - 90 | Consult your doctor |
| 4. blood pressure too high | 140 - 160 | 90 - 100 | Seek medical advice |
| 5. blood pressure far too high | 160 - 180 | 100 - 110 | Seek medical advice |
| 6. blood pressure dangerously high | 180 ↑ | 110 ↑ | Urgently seek medical advice! |

The higher value is the one that determines the evaluation. Example: a readout value between **150/85** or **120/98** mmHg indicates «blood pressure too high».

2. Using the Device for the First Time

Inserting the batteries

After you have unpacked your device, first insert the batteries. The battery compartment (5) is at the back of the device. Insert the batteries (4 x 1.5 V, size AA), thereby observing the indicated polarity.

Selecting the correct cuff

Microlife offers different cuff sizes. Select the cuff size to match the circumference of your upper arms (measured by close fitting in the centre of the upper arm).

| Cuff size | for circumference of upper arm |
|-----------|---------------------------------|
| S | 17 - 22 cm (6.75 - 8.75 inches) |
| M | 22 - 32 cm (8.75 - 12.5 inches) |
| L | 32 - 42 cm (12.5 - 16.5 inches) |
| M - L | 22 - 42 cm (8.75 - 16.5 inches) |

☞ Optional preformed cuffs «Easy» are available.

☞ Only use Microlife cuffs.

- ▶ Contact your local Microlife Service if the enclosed cuff ⑥ does not fit.
- ▶ Connect the cuff to the device by inserting the cuff connector ⑦ into the cuff socket ③ as far as it will go.

3. Taking a Blood Pressure Measurement using this Device

Checklist for taking a reliable measurement

1. Avoid activity, eating or smoking immediately before the measurement.
2. Sit down for at least 5 minutes before the measurement and relax.
3. Always measure on the same arm (normally left).
4. Remove close-fitting garments from the upper arm. To avoid constriction, shirt sleeves should not be rolled up - they do not interfere with the cuff if they are laid flat.
5. Always ensure that the correct cuff size is used (marking on the cuff).
 - Fit the cuff closely, but not too tight.
 - Make sure that the cuff is positioned 2 cm above the elbow.
 - The **artery mark** located on the cuff (ca. 3 cm long bar) must lie over the artery which runs down the inner side of the arm.
 - Support your arm so it is relaxed.
 - Ensure that the cuff is at the same height as your heart.
6. Press the ON/OFF button ① to start the measurement.
7. The cuff will now pump up automatically. Relax, do not move and do not tense your arm muscles until the measurement result is displayed. Breathe normally and do not talk.
8. When the correct pressure is reached, the pumping stops and the pressure falls gradually. If the required pressure was not reached, the device will automatically pump some more air into the cuff.
9. During the measurement, the heart symbol ⑬ flashes in the display and a beep sounds every time a heartbeat is detected.

10. The result, comprising the systolic ⑨ and the diastolic ⑩ blood pressure and the pulse rate ⑪ is displayed and a long beep is heard. Note also the explanations on further display symbols in this booklet.

11. When the device has finished measuring, remove the cuff.
12. Switch off the device. (The monitor does switch off automatically after approx. 1 min.).

☞ You can stop the measurement at any time by pressing the ON/OFF button (e.g. if you feel uneasy or an unpleasant pressure sensation).

4. Appearance of the Heart Arrhythmia Indicator for early Detection

This symbol ⑫ indicates that certain pulse irregularities were detected during the measurement. In this case, the result may deviate from your normal blood pressure – repeat the measurement. In most cases, this is no cause for concern. However, if the symbol appears on a regular basis (e.g. several times a week with measurements taken daily) we advise you to tell your doctor. Please show your doctor the following explanation:

Information for the doctor on frequent appearance of the Arrhythmia indicator

This device is an oscillometric blood pressure monitor that also analyses pulse frequency during measurement. The device is clinically tested.

The arrhythmia symbol is displayed after the measurement, if pulse irregularities occur during measurement. If the symbol appears more frequently (e.g. several times per week on measurements performed daily) we recommend the patient to seek medical advice. This device does not replace a cardiac examination, but serves to detect pulse irregularities at an early stage.

5. Data Memory

At the end of each measurement, this device automatically stores the result.

Viewing the stored values

Press the M-button ⑧ briefly, when the device is switched off. The display first shows «M» ⑮ and then a value, e.g. «M 17». This means that there are 17 values in the memory. The device then switches to the last stored result.

Pressing the M-button again displays the previous value. Pressing the M-button repeatedly enables you to move from one stored value to another.

Memory full



Pay attention that the maximum memory capacity of 30 is not exceeded. **When the memory is full, the old values are automatically overwritten with new ones.** Values should be evaluated by a doctor before the memory capacity is reached – otherwise data will be lost.

Clearing all values

If you are sure that you want to permanently remove all stored values, hold down the M-button (the device must have been switched off beforehand) until «CL» appears and then release the button. To permanently clear the memory, press the M-button while «CL» is flashing. Individual values cannot be cleared.

How not to store a reading

As soon as the reading is displayed press and hold the ON/OFF button ① until «M» ⑮ is flashing. Confirm to delete the reading by pressing the M-button ⑧.

6. Battery Indicator and Battery change

Low battery

When the batteries are approximately ¾ empty the battery symbol ⑭ will flash as soon as the device is switched on (partly filled battery displayed). Although the device will continue to measure reliably, you should obtain replacement batteries.

Flat battery – replacement

When the batteries are flat, the battery symbol ⑭ will flash as soon as the device is switched on (flat battery displayed). You cannot take any further measurements and must replace the batteries.

1. Open the battery compartment ⑤ at the back of the device.
2. Replace the batteries – ensure correct polarity as shown by the symbols in the compartment.

Which batteries and which procedure?

- ☞ Use 4 new, long-life 1.5 V, size AA batteries.
- ☞ Do not use batteries beyond their date of expiry.
- ☞ Remove batteries if the device is not going to be used for a prolonged period.

Using rechargeable batteries

You can also operate this device using rechargeable batteries.

- ☞ Only use «NiMH» type reusable batteries.
- ☞ Batteries must be removed and recharged when the flat battery symbol appears. They should not remain inside the device as they may become damaged (total discharge as a result of low use of the device, even when switched off).

- ☞ Always remove the rechargeable batteries if you do not intend to use the device for a week or more.
- ☞ Batteries cannot be charged in the blood pressure monitor. Recharge batteries in an external charger and observe the information regarding charging, care and durability.

7. Using a Mains Adapter

You can operate this device using the Microlife mains adapter (DC 6V, 600 mA).

- ☞ Only use the Microlife mains adapter available as an original accessory appropriate for your supply voltage.
- ☞ Ensure that neither the mains adapter nor the cable are damaged.

1. Plug the adapter cable into the mains adapter socket ④ in the blood pressure monitor.
2. Plug the adapter plug into the wall socket.

When the mains adapter is connected, no battery current is consumed.

8. Error Messages

If an error occurs during the measurement, the measurement is interrupted and an error message, e.g. «ERR 3», is displayed.

| Error | Description | Potential cause and remedy |
|---------|---------------------------------|--|
| «ERR 1» | Signal too weak | The pulse signals on the cuff are too weak. Re-position the cuff and repeat the measurement.* |
| «ERR 2» | Error signal | During the measurement, error signals were detected by the cuff, caused for instance by movement or muscle tension. Repeat the measurement, keeping your arm still. |
| «ERR 3» | No pressure in the cuff | An adequate pressure cannot be generated in the cuff. A leak may have occurred. Check that the cuff is correctly connected and is not too loose. Replace the batteries if necessary. Repeat the measurement. |
| «ERR 5» | Abnormal result | The measuring signals are inaccurate and no result can therefore be displayed. Read through the checklist for performing reliable measurements and then repeat the measurement.* |
| «HI» | Pulse or cuff pressure too high | The pressure in the cuff is too high (over 300 mmHg) OR the pulse is too high (over 200 beats per minute). Relax for 5 minutes and repeat the measurement.* |
| «LO» | Pulse too low | The pulse is too low (less than 40 beats per minute). Repeat the measurement.* |

* Please consult your doctor, if this or any other problem occurs repeatedly.

 If you think the results are unusual, please read through the information in «Section 1.» carefully.

9. Safety, Care, Accuracy Test and Disposal

Safety and protection

- This device may only be used for the purposes described in these instructions. The manufacturer cannot be held liable for damage caused by incorrect application.
- This device comprises sensitive components and must be treated with caution. Observe the storage and operating conditions described in the «Technical Specifications» section.
- Protect it from:
 - water and moisture
 - extreme temperatures
 - impact and dropping
 - contamination and dust
 - direct sunlight
 - heat and cold
- The cuffs are sensitive and must be handled with care.
- Only pump up the cuff once fitted.
- Do not use this device close to strong electromagnetic fields such as mobile telephones or radio installations.
- Do not use this device if you think it is damaged or notice anything unusual.
- Never open this device.
- If the device is not going to be used for a prolonged period the batteries should be removed.
- Read the additional safety information provided within the individual sections of this instruction manual.

 Ensure that children do not use this device unsupervised; some parts are small enough to be swallowed.

Device care

Clean the device only with a soft, dry cloth.

Cleaning the cuff

Carefully remove spots on the cuff with a damp cloth and soapsuds.

 **WARNING:** Do not wash the cuff in a washing machine or dishwasher!

Accuracy test

We recommend this device is tested for accuracy every 2 years or after mechanical impact (e.g. being dropped). Please contact your local Microlife-Service to arrange the test (see foreword).

Disposal



Batteries and electronic devices must be disposed of in accordance with the locally applicable regulations, not with domestic waste.

10. Guarantee

This device is covered by a **3 year guarantee** from the date of purchase. The guarantee is valid only on presentation of the guarantee card completed by the dealer (see back) confirming date of purchase or the receipt.

- Batteries, cuff and wearing parts are not included.
- Opening or altering the device invalidates the guarantee.
- The guarantee does not cover damage caused by improper handling, discharged batteries, accidents or non-compliance with the operating instructions.

Please contact your local Microlife-Service (see foreword).

11. Technical Specifications

Operating temperature: 10 - 40 °C / 50 - 104 °F
15 - 95 % relative maximum humidity

Storage temperature: -20 - +55 °C / -4 - +131 °F
15 - 95 % relative maximum humidity

Weight: 400 g (including batteries)

Dimensions: 140 x 120 x 70 mm

Measuring procedure: oscillometric, corresponding to Korotkoff method: Phase I systolic, Phase V diastolic

Measurement range: 20 - 280 mmHg – blood pressure
40 - 200 beats per minute – pulse

Cuff pressure display range: 0 - 299 mmHg

Resolution: 1 mmHg

Static accuracy: pressure within ± 3 mmHg

Pulse accuracy: ± 5 % of the readout value

Voltage source: 4 x 1.5 V Batteries; size AA
Mains adapter DC 6V, 600 mA (optional)
Reference to standards: EN 1060-1 / 3 / 4; IEC 60601-1; IEC 60601-1-2 (EMC)

This device complies with the requirements of the Medical Device Directive 93/42/EEC.

Technical alterations reserved.

- ① Dugme ON/OFF (uključi/isključi)
- ② Ekran
- ③ Utičnica za manžetnu
- ④ Utičnica za strujni adapter
- ⑤ Odeljak za baterije
- ⑥ Manžetna
- ⑦ Priklučak za manžetnu
- ⑧ M-dugme (Memorija)

Ekran

- ⑨ Sistolna vrednost
- ⑩ Dijastolna vrednost
- ⑪ Brzina pulsa
- ⑫ Indikator srčane aritmije
- ⑬ Puls
- ⑭ Prikaz baterije
- ⑮ Sačuvana vrednost

Poštovani korisniče,

Vaš novi Microlife merač krvnog pritiska je pouzdan medicinski instrument za obavljanje merenja krvnog pritiska na nadlaktici. Jednostavan je za upotrebu, precizan i preporučuje se za merenje krvnog pritiska u Vašem domu. Aparat je napravljen u saradnji sa lekarima, a klinički testovi su pokazali da je tačnost merenja veoma visoka.*

Molimo da veoma pažljivo proučite uputstva, kako biste razumeli sve funkcije i informacije vezane za bezbednost. Mi želimo da budete srećni sa svojim Microlife proizvodom. Ukoliko imate bilo kakva pitanja, probleme ili želite da naručite rezervne delove, molimo kontaktirajte Vaš lokalni Microlife – Uslužni servis. Vaš prodavac ili apoteka će Vam dati adresu Microlife dobavljača u Vašoj zemlji. Kao alternativa, možete da posetite internet sajt www.microlife.com, gde ćete naći mnoštvo dragocenih informacija o našim proizvodima.

Ostanite zdravo – Microlife AG!

** Aparat koristi istu mernu tehnologiju kao i visoko odlikovani «BP 3BTO-A» model testiran u skladu sa Pravilnikom Britanskog Društva za Hiperteniziju (BHS).*



Pre upotrebe pažljivo pročitajte uputstvo.



Tip BF

Sadržaj

1. Važne informacije o krvnom pritisku i samomerenju

- Kako da procenim vrednost svog krvnog pritiska?

2. Korišćenje aparata po prvi put

- Postavljanje baterija
- Izbor odgovarajuće manžetne

3. Obavljanje merenja krvnog pritiska korišćenjem aparata

4. Pojavljivanje indikatora srčane aritmije za rano otkrivanje

5. Memorisanje podataka

- Pregled sačuvanih vrednosti
- Popunjena memorija
- Brisanje svih vrednosti
- Kako ne sačuvati rezultat očitavanja

6. Indikator baterije i zamena baterija

- Baterije skoro istrošene
- Istrošene baterije – zamena
- Koje baterije i kakav je postupak?
- Korišćenje baterija koje se pune

7. Korišćenje strujnog adaptera

8. Poruke o greškama

9. Bezbednost, čuvanje, test ispravnosti i odlaganje

- Bezbednost i zaštita
- Održavanje aparata
- Čišćenje manžetni
- Test ispravnosti
- Odlaganje

10. Garancija

11. Tehničke specifikacije

Garantni list (pogledajte poslednju stranu)

1. Važne informacije o krvnom pritisku i samomerenju

- **Krvni pritisak** je pritisak krvi koja protiče kroz arterije nastao pumpanjem srca. Uvek se mere dve vrednosti, **sistolna** (gornja) vrednost i **dijastolna** (donja) vrednost.
- Aparat takođe pokazuje **brzinu pulsa** (broj otkucaja srca u minuti).
- **Konstantno visok krvni pritisak može oštetiti Vaše srce i mora biti lečen od strane lekara!**
- Uvek prodiskutujte o vrednosti krvnog pritiska sa lekarom i konsultujte ga ukoliko primetite bilo šta neuobičajeno ili niste sigurni. **Nikada se nemojte oslanjati na jedno očitavanje krvnog pritiska.**
- Unesite svoje rezultate u **dnevnik krvnog pritiska** koji je u prilogu. Ovo će omogućiti lekaru brz pregled stanja.
- Postoji mnogo uzroka **povećanja vrednosti krvnog pritiska**. Lekar će Vam ih detaljnije objasniti i predložiti odgovarajuću terapiju. Pored lekova, Vaš krvni pritisak takođe mogu da snize tehnike relaksacije, gubitak težine i vežbe.
- **Ni pod kojim uslovima ne smete povećavati doze bilo kog leka koje Vam je prepisao lekar!**
- U zavisnosti od fizičkog naprezanja i kondicije, krvni pritisak podleže velikim variranjima, u toku dana. **Zbog toga bi trebalo da merite pritisak u istim smirenim uslovima i kada ste opuštteni!** Vršite merenja najmanje dva puta dnevno, jednom ujutro, jednom uveče.
- Potpuno je normalno da dva merenja obavljena jedno za drugim daju značajno **različite rezultate**.
- **Sasvim** su normalna odstupanja između merenja koje je uradio Vaš doktor, ili onog koje ste uradili u apoteci, i merenja koje ste uradili kod kuće, iz razloga što su ove situacije potpuno različite.
- **Nekoliko merenja** daje mnogo jasniju sliku, nego jedno jedino.
- Između dva merenja **napravite kratku pauzu** od najmanje 15 sekundi.
- Ukoliko ste **trudni**, treba veoma pažljivo da pratite krvni pritisak, jer on može drastično da se menja u ovom razdoblju!
- Ukoliko patite od **nepravilnih otkucaja srca** (aritmija, vidite «Odeljak 4.»), merenja izvršena na ovom aparatu treba uzeti u obzir tek nakon konsultacije sa lekarom.
- **Prikaz pulsa nije odgovarajući za proveru frekvencije kod ugrađenog pejsmejera!**

Kako da procenim vrednost svog krvnog pritiska?

Tabela sa klasifikacijom vrednosti krvnog pritiska kod odraslih, u skladu sa Svetskom zdravstvenom organizacijom (WHO) u 2003. godini. Podaci su u mmHg.

| Nivo | Sistolni | Dijastolni | Preporuke |
|--------------------------------|-----------|------------|---------------------------------|
| krvni pritisak suviše nizak | ↓ 100 | ↓ 60 | Konsultovati se sa lekarom |
| 1. krvni pritisak optimalan | 100 - 120 | 60 - 80 | Samokontrola |
| 2. krvni pritisak normalan | 120 - 130 | 80 - 85 | Samokontrola |
| 3. krvni pritisak malo povišen | 130 - 140 | 85 - 90 | Konsultovati se sa lekarom |
| 4. krvni pritisak veoma visok | 140 - 160 | 90 - 100 | Potražite lekarski savet |
| 5. krvni pritisak previsok | 160 - 180 | 100 - 110 | Potražite lekarski savet |
| 6. krvni pritisak opasno visok | 180 ↑ | 110 ↑ | Hitno potražite lekarski savet! |

Viša vrednost je ona koja određuje procenu. Primer: iščitavanje vrednosti između 150/85 i 120/98 mmHg ukazuje na «krvni pritisak veoma visok».

2. Korišćenje aparata po prvi put

Postavljanje baterija

Pošto ste otpakovali uređaj, prvo postavite baterije. Odeljak za baterije ⑤ nalazi se na donjem delu uređaja. Postavite baterije (4 x 1.5V baterije, veličine AA), vodeći računa o polaritetu.

Izbor odgovarajuće manžetne

Microlife nudi različite veličine manžetni. Izaberite manžetnu koja odgovara obimu Vaše nadlaktice (izmeren obim na sredini nadlaktice).

| Veličina manžetne | Za obim nadlaktice |
|-------------------|-------------------------------|
| S | 17 - 22 cm (6,75 - 8,75 inča) |
| M | 22 - 32 cm (8,75 - 12,5 inča) |
| L | 32 - 42 cm (12,5 - 16,5 inča) |
| M - L | 22 - 42 cm (8,75 - 16,5 inča) |

☞ Opcije prikazanih manžetni «Easy/jednostavna» su dostupne.

☞ Koristite isključivo Microlife manžetne.

- ▶ Kontaktirajte Vaš lokalni Microlife servis, ukoliko Vam priložene manžetne ⑥ ne odgovaraju.
- ▶ Povežite manžetnu za aparat, ubacivanjem priključka za manžetnu ⑦ u utičnicu za manžetnu ③, dokle god može da uđe.

3. Obavljanje merenja krvnog pritiska korišćenjem aparata

Podsetnik za obavljanje pouzdanog merenja

1. Izbegavajte aktivnosti, jelo i pušenje neposredno pre merenja.
2. Sedite najmanje 5 minuta pre merenja i opustite se.
3. Uvek vršite merenje na istoj ruci (obično leva ruka).
4. Skinite delove odeće i sat npr, tako da Vam nadlaktica bude slobodna. Kako biste izbegli stezanje, rukavi odeće ne bi trebalo da budu zarolani – ne ometaju funkcionisanje manžetne ukoliko su ispravljani.
5. Uvek proverite da li koristite ispravnu veličinu manžetne (prikazano na manžetni).
 - Dobro zategnite manžetnu, ali ne previše stegnuto.
 - Proverite da li je manžetna 2 cm iznad lakta.
 - **Oznaka arterije** na manžetni (3 cm duga traka) mora da leži preko arterije koja se spušta sa unutrašnje strane ruke.
 - Poduprite ruku tako da bude opuštena.
 - Proverite da li je manžetna u istoj ravni sa srcem.
6. Pritisnite uključiti/isključiti dugme ① kako biste počeli merenje.
7. Manžetna će se sada automatski pumpati. Opustite se, nemojte se pomerati i napinjati mišiće ruke dok se na displeju ne očitaju rezultati merenja. Dišite normalno i ne pričajte.
8. Kada je dostignut odgovarajući pritisak, pumpanje će prestati i pritisak će postepeno opadati. Ukoliko nije dosegnut potreban pritisak, aparat će automatski dopumpati još vazduha u manžetnu.
9. Tokom merenja, detektor pulsa ⑬ treperi na ekranu i začuće se bip zvuk svaki put kad je nađen otkucaj srca.
10. Rezultat, koji obuhvata sistolni ⑨ i dijastolni ⑩ krvni pritisak i brzinu pulsa ⑪, prikazan je na ekranu i čuje se dugačko bip. Obratite pažnju na objašnjenja vezana za druge simbole na displeju koja ćete naći u ovom priručniku.
11. Kada je merenje završeno, skinite manžetnu.
12. Isključite uređaj. (Monitor će se isključiti automatski nakon otprilike 1 min.).

 U bilo kom trenutku možete zaustaviti merenje pritiskom na dugme uključiti/isključiti (npr. ukoliko imate nelagodan i neprijatan osećaj).

4. Pojavljivanje indikatora srčane aritmije za rano otkrivanje

Znak  ukazuje da su tokom merenja otkrivene određene nepravilnosti pulsa. U ovom slučaju, rezultati se mogu razlikovati od Vašeg uobičajenog krvnog pritiska - ponovite merenje. U većini slučajeva, ovo nije razlog za brigu. Ipak, ukoliko se ovaj znak često pojavljuje u toku merenja (npr. nekoliko puta nedeljno, ukoliko merenja obavljate dnevno), savetujemo da se obratite lekaru. Molimo da svom lekaru pokažete sledeće objašnjenje:

Objašnjenje za lekara o čestom pojavljivanju indikatora aritmije

Ovaj instrument je oscilometrijski aparat za merenje krvnog pritiska koji takođe tokom merenja daje podatke o puls. Aparat je klinički testiran



Znak za aritmiju se prikazuje nakon merenja, ukoliko se tokom merenja pojave nepravilnosti otkucaja srca. Ukoliko se znak pojavljuje dosta često (npr. nekoliko puta nedeljno, ukoliko se merenja obavljaju dnevno), pacijentu se preporučuje da zatraži savet lekara.

Aparat nije zamena za kardiološki pregled, već služi da otkrije nepravilnosti pulsa u ranoj fazi.

5. Memorisanje podataka

Po završetku merenja, ovaj aparat automatski čuva sve rezultate.

Pregled sačuvanih vrednosti

Pritisnite M-dugme  na kratko, kada je instrument isključen. Na ekranu se prvo pokazuje znak «M»  a zatim vrednost, na primer «M 17». To znači da ima 17 vrednosti sačuvanih u memoriji. Instrument zatim prebacuje poslednju sačuvanu vrednost. Ponovnim pritiskom na M-dugme na displeju će se prikazati prethodni rezultat. Ponavljeni pritisak na M-dugme omogućava Vam da prelazite sa jedne na drugu sačuvanu vrednost.

Popunjena memorija





Obratite pažnju da se ne prekorači maksimalni kapacitet memorije od 30 merenja. **Kada je memorija puna, stare vrednosti su automatski prebrisane novim vrednostima.**

Vrednosti treba da budu procenjene od strane lekara pre nego što se napuni memorija-u suprotnom podaci će se izgubiti.

Brisanje svih vrednosti

Ako ste sigurni da želite trajno da uklonite sve sačuvane vrednosti, pritisnite i zadržite M-dugme (instrument mora biti isključen pre toga) dok se ne pojavi «CL» i onda pustite dugme. Da biste potpuno izbrisali memoriju, pritisnite M-dugme dok «CL» treperi. Pojedinačne vrednosti se ne mogu izbrisati.

Kako ne sačuvati rezultat očitavanja

Čim se rezultat očitavanja pojavi na ekranu pritisnite i držite dugme uključiti/isključiti  dok god «M»  svetluca na ekranu. Potvrdite brisanje očitavanja pritiskom na M-dugme .

6. Indikator baterije i zamena baterija

Baterije skoro istrošene



Kada su baterije iskorišćene skoro $\frac{3}{4}$ počeo da svetli simbol za baterije  čim se aparat uključiti (na displeju je prikazana delimično napunjena baterija). Iako će aparat nastaviti pouzdano da meri, trebalo bi da nabavite nove baterije.

Istrošene baterije – zamena



Kada su baterije prazne, simbol za baterije  će početi da trepće čim se aparat uključiti (pokazuje se prazna baterija). Ne možete vršiti dalja merenja i morate zameniti bateriju.

1. Otvorite odeljak za baterije  na poledini instrumenta.
2. Zamenite baterije – obratite pažnju na polaritet, stavite kako pokazuju simboli unutar odeljka

Koje baterije i kakav je postupak?

-  Ubacite 4 nove, dugotrajne baterije od 1.5V, veličine AA.
-  Ne koristite baterije nakon datuma isteka.
-  Izvadite baterije, ukoliko se aparat neće koristiti duže vreme.

Korišćenje baterija koje se pune

- Možete, takođe, za rad ovog aparata koristiti baterije koje se pune.
-  Molimo da koristite isključivo vrstu «NiMH» baterija koje se pune.
 -  Ukoliko se pojavi simbol za bateriju (prazna baterija), baterije moraju biti izvađene i napunjene. One ne smeju ostati unutar aparata, jer ga mogu oštetiti (potpuno ispražnjene baterije kao rezultat slabog korišćenja aparata, čak i kad je isključen).
 -  Ukoliko ne namerevate da koristite aparat nedelju dana i više, uvek izvadite ovu vrstu baterije.

 Baterije se ne mogu puniti preko merača krvnog pritiska. Ove baterije puniti putem posebnog punjača i obratite pažnju na informacije koje se tiču punjenja, održavanja i trajanja.

7. Korišćenje strujnog adaptera

Ovaj aparat može se koristiti i uz pomoć Microlife strujnog adaptera (DC 6V, 600Ma).

 Koristite samo Microlife strujni adapter, kao originalni dodatak, za adekvatno napajanje.

 Proverite da li su strujni adapter i kabal oštećeni.

1. Uključite kabal adaptera u utičnicu za strujni adapter  ovog aparata.

2. Priklučen adapter za aparat priključite i za zidni utikač. Kada je strujni adapter povezan, baterije nisu u upotrebi.

8. Poruke o greškama

Ukoliko tokom merenja dođe do greške, merenje se prekida i na displeju pokazuje da je reč o grešci, npr. «ERR 3».

| Greška | Opis | Mogući uzrok i njegovo otklanjanje |
|---------|--|--|
| «ERR 1» | Signal suviše slab | Pulsni signal na manžetni je suviše slab. Ponovo namesite manžetnu i ponovite merenje.* |
| «ERR 2» | Greška u signalu | Tokom merenje, greška u signalu je otkrivena preko manžetne, izazvana na trenutak zbog pomeranja ili napetosti mišića. Ponovite merenje, držeci mirno ruku. |
| «ERR 3» | Nema pritiska u manžetni | U manžetni može doći do stvaranja neodgovarajućeg pritiska. Možda je došlo do curenja. Proverite da li je manžetna ispravno nameštena i da nije suviše opuštena. Zamenite baterije ukoliko je to potrebno. Ponovite merenje. |
| «ERR 5» | Nemogući rezultat | Signali za merenje su netačni, zbog čega se na displeju ne može pokazati rezultat. Proverite podsetnik za pravilno merenje i ponovite merenje.* |
| «HI» | Puls ili pritisak u manžetni je suviše visok | Pritisak u manžetni je suviše visok (preko 300 mmHg) ili je puls suviše visok (preko 200 otkucaja u minuti). Opustite se na 5 minuta i ponovite merenje.* |

| Greška | Opis | Mogući uzrok i njegovo otklanjanje |
|--------|----------------------|---|
| «LO» | Puls je suviše nizak | Puls je suviše nizak (niži od 40 otkucaja u minuti). Ponovite merenje.* |

* Molimo obratite se Vašem lekaru, ukoliko se bilo koji od ovih problema kontinuirano ponavlja.

 Ukoliko smatrate da rezultati nisu uobičajeni, pažljivo pročitajte «Odeljak 1.» u uputstvu.

9. Bezbednost, čuvanje, test ispravnosti i odlaganje

Bezbednost i zaštita

- Ovaj uređaj se može koristiti isključivo u svrhe opisane u ovom uputstvu. Proizvođač se ne može smatrati odgovornim za oštećenja nastala neadekvatnom upotrebom.
- Ovaj uređaj sadrži osetljive komponente i sa njim se mora oprezno rukovati. Pogledati čuvanje i uslove rada opisane u delu «Tehničke specifikacije».
- Zaštite ga od:
 - vode i vlage
 - ekstremnih temperatura
 - udara i padova
 - prljavštine i prašine
 - direktne sunčeve svetlosti
 - toplote ili hladnoće
- Manžete su osetljive i njima se mora pažljivo rukovati.
- Tek kada podesite manžetnu, napumpajte je.
- Ne koristite aparat u blizini jakih elektromagnetnih talasa, kao što su mobilni telefon ili radio instalacije.
- Nemojte koristiti ovaj uređaj ukoliko smatrate da je oštećen ili primetite nešto neobično.
- Nikada nemojte otvarati ovaj uređaj.
- Ukoliko aparat nećete koristiti duži period, baterije treba izvaditi.
- Čitajte dalja sigurnosna uputstva u odeljcima ovog uputstva za upotrebu.

 Obezbedite da deca ne koriste ovaj uređaj bez nadzora; pojedini delovi su dovoljno mali da mogu biti progutani.

Održavanje aparata

Čistite aparat isključivo mekanom, suvom krpom.

Čišćenje manžetni

Pažljivo uklonite mrlje sa manžetne vlažnom krpom i sapunicom.



UPOZORENJE: Nemojte prati manžetu u već mašini ili mašini za pranje sudova!

Test ispravnosti

Preporučujemo da testirate ispravnost aparata svake 2 godine ili nakon mehaničkog udara (npr. ukoliko je pao). Molimo kontaktirajte Vaš lokalni Microlife-Servis da zakazete test (pročitati predgovor).

Odlaganje



Baterije i električni aparati moraju biti uklonjeni u skladu sa lokalnim važećim pravilima, ne sa otpadom iz domaćinstva.

10. Garancija

Aparat je pod **garancijom 3 godina**, počev od datuma kupovine. Garancija je validna jedino uz garantni list, popunjen od strane prodavca (videti drugu stranu), kojim se potvrđuje datum kupovine ili računa.

- Baterije, manžetna i potrošni delovi nisu uključeni.
- Otvaranje ili prepravljnje aparata čini garanciju nevažećom.
- Garancija ne pokriva štete izazvane nepropisnim rukovanjem, procurelim baterijama, nezgodama ili nepridržavanjem uputstva za upotrebu.

Molimo kontaktirajte Vaš lokalni Microlife-Servis (pročitati predgovor).

11. Tehničke specifikacije

Radna temperatura: 10 - 40 °C / 50 - 104 °F
15 - 95 % relativna maksimalna vlažnost

Temperatura čuvanja: -20 - +55 °C / -4 - +131 °F
15 - 95 % relativna maksimalna vlažnost

Težina: 400 g (uključujući baterije)

Dimenzije: 140 x 120 x 70 mm

Postupak merenja: oscilometrijski, u skladu sa Korotkoff-ovom metodom: Faza I sistolna, Faza V dijastolna

Raspon merenja: 20 - 280 mmHg – krvni pritisak
40 - 200 otkucaja u minuti – puls

Prikazani raspon pritiska u manžetni: 0 - 299 mmHg

Rezolucija: 1 mmHg
Statička preciznost: Pritisak u opsegu ± 3 mmHg
Preciznost pulsa: ± 5 % od iščitane vrednosti
Izvor napona: 4 x 1.5V baterije, veličine AA
Strujni adapter DC 6V, 600Ma (optimalno)
Referentni standardi: EN 1060-1 /-3 /-4; IEC 60601-1;
IEC 60601-1-2 (EMC)

Ovaj aparat uskladen je sa zahtevima Direktive 93/42/EEC za medicinska sredstva.

Zadržano pravo na tehničke izmene.