

FT-700(R/L) FULLY AUTOMATED BLOOD PRESSURE MONITOR OWNER'S MANUAL

- ONE TOUCH operation
- WIDE LCD screen
- QUICK measure
- HIGH accuracy
- THERMAL HIGH SPEED printer
- VOICE message
- CARD using



JAWON
MEDICAL CO., LTD.



The device bears the CE label in accordance with the provisions of Medical Device Directive 93/42/EEC.

THE PERSONS RESPONSIBLE FOR PLACING DEVICES ON THE EC MARKET UNDER MDD 93/42/EEC



Jawon Medical Co.,Ltd.

29, Gongdan 4-ro, Jillyang-eup, Gyeongsan-si, Gyeongsangbuk-do,
38470, Republic of Korea

TEL: 82-53-856-0993, FAX: 82-53-856-0995



VITAKO Sp. Z o.o.

UL. MALEJ SYRENKI 2 71-790 SZCZECIN, POLAND

TEL: 91 8522900 / 901, FAX: 91 8522910

TABLE OF CONTENTS

• INTRODUCTION	4
1. INTENDED USE.....	4
2. WORD DEFINITIONS.....	4
3. CLASSIFICATION AND COMPLIANCE.....	5
4. SAFETY PRECAUTIONS.....	5
5. SAFETY SYMBOLS AND INFORMATION.....	8
6. Guidance for Electromagnetic compatibility (EMC)	10
• TERMS OF EACH PART AND FUNCTIONS	15
1. FRONT PART.....	15
2. PRINTER.....	17
3. REAR PART.....	18
4. ACCESSORIES.....	20
5. OPTIONS.....	20
• INSTALLATION	21
1. CONNECTING POWER CABLE.....	21
2. ASSEMBLING OF ARM SUPPORTER.....	21
3. LOADING THE PRINT PAPER.....	22
4. CONNECTING PORTS.....	22
5. SETTING TIME AND DATE.....	23
• MEASUREMENT	25
1. CAUTIONS FOR MEASUREMENT.....	25
2. MEASUREMENT.....	26
3. DATA ON MEASUREMENT BY PRINTER.....	29
• MAINTENANCE	30
• ERROR&REPAIR	32
• AFTER SERVICE	33
1. AFTER SERVICE.....	33
2. PACKING AND TRANSPORT.....	33
• SPECIFICATION	34
• WARRANTY	35

INTRODUCTION

We highly appreciate that you chose our company's product.

You are kindly requested to be familiar with these directions before using this product and always keep it together with the product. In case you are not sure about any directions or problems arising while using the product, please contact our service center.

We will provide you with detailed instructions.

1. INTENDED USE

This device is a medical equipment that can check not only blood pressure(systolic blood pressure, diastolic blood pressure, mean arterial blood pressure, pulse Pressure) but also pulse rate.

2. WORD DEFINITIONS

To ensure safe operation and long term performance stability, it is essential that you fully understand the functions, operating and maintenance instructions by reading this manual before operating your unit.

Particular attention must be paid to all warnings, cautions and notes incorporated herein.

The following conventions are used throughout the manual to denote information of special emphasis.

Warning



"Warning" indicates important information to the presence of a hazard which may cause severe personal injury, death or substantial property damage if the warning is ignored.

Caution



"Caution" indicates important information to the presence of a hazard which may cause minor personal injury or property damage if the caution is ignored.

Note



"Notice" indicates important information to notify installation, operation or maintenance of this device. "Notice" is important but not hazard-related. Hazard warnings are not included here.

3. CLASSIFICATION AND COMPLIANCE

1) This device is classified as;

- Class 1 type-BF against electric shock
- Ordinary equipment without protection against ingress of water
- Equipment not suitable for use in presence of a flammable anesthetic mixture by standard of EN 60601-1: 2006(Basic safety and essential performance of Medical Electrical Equipment)

2) This device is complied with Class A for Noise-Emission, Level B for Noise-immunity, by standard of IEC 60601-1-2:2007(Electromagnetic Compatibility Requirements).

3) This device is complies with the EN 1060-1: 1995+A2:2009 Non-invasive Sphygmomanometers general requirements as well as EN 1060-3: 1997+A2:2009 supplementary requirements for electro-mechanical blood pressure measuring systems.

4. SAFETY PRECAUTIONS

This device is designed and manufactured with consideration of safety of the operator and subject and also to the reliability of the unit.

The following precautions must be observed for additional safety;

 1) The unit must be operated only by, or under supervision of a qualified person with our company or our distributors.

2) This device is specified as Class 1 type BF unit under the standard of IEC 60601-1:2005(Safety of Medical Electrical Equipment).

 Do not touch or handle inner side of the system at any time.

 The INTERNAL ELECTRICAL POWER SOURCE is to be used if the integrity of the PROTECTIVE EARTH CONDUCTOR or the protective earthing system in the installation is in doubt.

 3) Do not modify the unit. If any modification is needed, ask our company or its authorized dealer for service.

4) The unit has previously been adjusted in the factory for optimum performance.

 Do not attempt to adjust switches or any other things except those specified in this manual for operation.

 5) If you have experienced any trouble with the unit, switch it off immediately, and contact our company or its authorized dealer for assistance.

6) If you plan to connect any device of other manufacturers electrically or mechanically to the unit, contact our company or its authorized dealer for instructions before doing so.

When you connect computer or other system to the unit (RS-232C), the attached systems should be those certified by IEC 60950 or equivalent standards for data processing equipment.

Configurations shall comply with the system standard IEC 60601-1:2005.

Everybody who connects additional equipment to the signal input part or signal output part configures a medical system standard IEC 60601-1:2005.

If in doubt, consult the A/S department of local distributor.

- ⚠ 7) Avoid the following environments for storage;
- Where the ambient temperature falls -20°C or exceeds 60°C .
 - Where the atmospheric pressure falls below 70kPa (700mbar) or exceeds 106kPa (1060mbar).
 - Where the humidity is over 95% non-condensing.
 - Where the unit is exposed to spray or splashing water.
 - Where the unit is exposed to dust.
 - Where the unit is exposed to water vapor.
 - Where the unit is exposed to salty atmosphere.
 - Where the unit is exposed to explosive gas.
 - Where the unit is exposed to excessive shocks or vibrations.
 - Where the angle of inclination of mounting surface exceeds 10 degrees.
 - Where the unit is exposed to direct sunlight.
- ⚠ 8) This equipment has been tested and found to comply with the limits for medical devices to the IEC 60601-1-2:2007. These limits are designed to provide reasonable protection against harmful interference in a typical medical installation. This equipment generates uses and can radiate radio frequency energy and, if not installed and used in accordance with the instructions, may cause harmful interference to other devices in the vicinity. However, there is no guarantee that interference will not occur in a particular installation. If this equipment does cause harmful interference to other devices, which can be determined by turning the equipment off and on, the user is encouraged to try to correct the interference by one or more of the following measures:
- Reorient or relocate the receiving device.
 - Increase the separation between the equipment.
 - Connect the equipment into an outlet on a circuit different from that to which the other device(s) are connected.
 - Consult the manufacturer or field service technician for help.
- ⊘ 9) Do not to touch signal input, signal output or other connectors, and the patient simultaneously.
- ⚠ 10) a statement that MEDICAL ELECTRICAL EQUIPMENT needs special precautions regarding EMC and needs to be installed and put into service according to the EMC information provided in the ACCOMPANYING DOCUMENTS;
- ⚠ 11) a statement that portable and mobile RF communications equipment can affect MEDICAL ELECTRICAL EQUIPMENT.
- ⚠ 12) Please consult a physician or a trained health professional for interpretation of measurement results.

Caution

1. Measurements may be impaired if this device is used near televisions, microwave ovens, X-ray equipment or other devices with strong electrical fields. To prevent such interference, use the meter at a sufficient distance from such devices or turn them off.
2. Incorrect operation or failure of user to maintain the unit spares the manufacturer or his agent of the responsibility for system's non-compliance with specifications or responsibility for any damage or injury.

Caution

This manual is made for informational purpose and this manual and product are not meant to be a substitute for the advice provided by your own physician or other medical problem. You should not use the information contained in the product for diagnosis or treatment of health problem or prescription of medication by yourself.

If you have or suspect that you have a medical problem, consult with your physician promptly.





Defective unit or accessories must be packed in the replacement cartons to be shipped off from you to our company.











Shipping and insurance costs for return of defective unit must be prepaid by the users.

5. SAFETY SYMBOLS AND INFORMATION

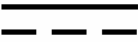
The International Electrotechnical Commission (IEC) has established a set of symbols for medical electrical equipment which classifies a connection or warning of any potential hazard.

The classifications and symbols are shown below. Save these instructions for your safety.

	<p>Degree of protection against electric shock: TYPE BF</p>
	<p>Please observe operating instructions</p>
	<p>General warning sign</p>
	<p>General prohibition sign</p>
	<p>General mandatory action sign</p>
	<p>Caution</p>
	<p>Waste Electrical and Electronic Equipment (WEEE) The device could be sent back to the manufacturer for recycling or proper disposal after their useful lives. Alternatively the device shall be disposed in accordance with national laws after their useful lives.</p>
	<p>"OFF" (only for a part of equipment)</p>

	<p>"ON" (only for a part of equipment)</p>
	<p>This symbol is used inside system. Identifies the point where the safety ground of the system is fastened to the chassis.</p>
	<p>Do not open. This is for factory only.</p>
	<p>Alternating current</p>
	<p>Direct current</p>
	<p>Date of manufacture</p>
	<p>Manufacturer</p>
	<p>Non-ionizing radiation</p>
	<p>This product complies with the Council Directive 93/42/EC regarding medical devices, which bears the mark CE 0197 (TUV Rheinland GmbH). Units with CE marks are subject to quality system audits in accordance with this Directive.</p>
	<p>Serial No.</p>

6. Guidance for Electromagnetic compatibility (EMC)

Details about the electromagnetic compatibility (EMC) of the FT-700 (R/L) are given below. Before using the FT-700 (R/L), be sure to read and understand the following information.

1) Guidance and manufacturer's declaration – electromagnetic emissions

The FT-700 (R/L) is intended for use in the electromagnetic environment specified below. The customer or the user of the FT-700 (R/L) should assure that it is used in such an environment.

Emissions test	Compliance	Electromagnetic environment – guidance
RF emissions CISPR 11	Group 1	The FT-700 (R/L) uses RF energy only for its internal function. Therefore, its RF emissions are very low and are not likely to cause any interference in nearby electronic equipment.
RF emissions CISPR 11	Class B	The FT-700 (R/L) is suitable for use in all establishments, including domestic establishments and those directly connected to the public low-voltage power supply network that supplies buildings used for domestic purposes.
Harmonic emissions IEC 61000-3-2	Class A	
Voltage fluctuations/ flicker emissions IEC 61000-3-3	Compliance	

2) Guidance and manufacturer's declaration – electromagnetic immunity

The FT-700 (R/L) is intended for use in the electromagnetic environment specified below. The customer or the user of the FT-700 (R/L) should assure that it is used in such an environment.

Immunity test	IEC 60601 test level	Compliance level	Electromagnetic environment-guidance
Electrostatic discharge(ESD) IEC 61000-4-2	±6kV: Contact ±8kV: Air	±6kV: Contact ±8kV: Air	Floors should be wood, concrete or ceramic tile. If floors are covered with synthetic material, the relative humidity should be at least 30 %.
Electrical fast transition/burst IEC 61000-4-4	±2kV: Power supply lines ±1kV: Input/output lines	±2kV: Power supply lines ±1kV: Input/output	Mains power quality should be that of a typical commercial or hospital environment.

		lines	
Surge IEC 61000-4-5	±1 kV differential mode ±2 kV common mode	±1 kV differential mode ±2 kV common mode	Mains power quality should be that of a typical commercial or hospital environment.
Voltage drops, dips, and fluctuations of input power supply line IEC 61000-4-11	<5 % <i>UT</i> (>95 % dip in <i>UT</i>) for 0,5 cycle 40 % <i>UT</i> (60 % dip in <i>UT</i>) for 5 cycles 70 % <i>UT</i> (30 % dip in <i>UT</i>) for 25 cycles <5 % <i>UT</i> (>95 % dip in <i>UT</i>) for 5 sec	<5 % <i>UT</i> (>95 % dip in <i>UT</i>) for 0,5 cycle 40 % <i>UT</i> (60 % dip in <i>UT</i>) for 5 cycles 70 % <i>UT</i> (30 % dip in <i>UT</i>) for 25 cycles <5 % <i>UT</i> (>95 % dip in <i>UT</i>) for 5 sec	Mains power quality should be that of a typical commercial or hospital environment. If the user of the FT-700 (R/L) requires continued operation during power mains interruptions, it is recommended that the FT-700 (R/L) be powered from an uninterruptible power supply or a battery.
Magnetic field of commercial frequency (50/60Hz) IEC 61000-4-8	3 A/m	3 A/m	Power frequency magnetic fields should be at levels characteristic of a typical location in a typical commercial or hospital environment.

Note



UT is the a.c. mains voltage prior to application of the test level.

3) Guidance and manufacturer's declaration – electromagnetic immunity 2

The FT-700 (R/L) is intended for use in the electromagnetic environment specified below. The customer or the user of the FT-700 (R/L) should assure that it is used in such an environment.

Immunity test	IEC 60601 test level	Compliance level	Electromagnetic environment-guidance
Conducted RF IEC 61000-4-6	3 Vrms 150 kHz to 80 MHz	3 Vrms	<p>Portable and mobile RF communications equipment should be used no closer to any part of the FT-700 (R/L), including cables, than the recommended separation distance calculated from the equation applicable to the frequency of the transmitter.</p> <p>Recommended separation distance</p> $d = 1.2\sqrt{P}$ $d = 1.2\sqrt{P} \text{ 80 MHz to 900 MHz}$ $d = 2.3\sqrt{P} \text{ 900 MHz to 2,5 GHz}$
Radiated RF IEC 61000-4-3	3 V/m 80 MHz to 2,5 GHz	3 V/m	<p>where P is the maximum output power rating of the transmitter in watts (W) according to the transmitter manufacturer and d is the recommended separation distance in meters (m).</p> <p>Field strengths from fixed RF transmitters, as determined by an electromagnetic site survey,^a should be less than the compliance level in each frequency range.^b</p> <p>Interference may occur in the vicinity of equipment marked with the following symbol:</p>

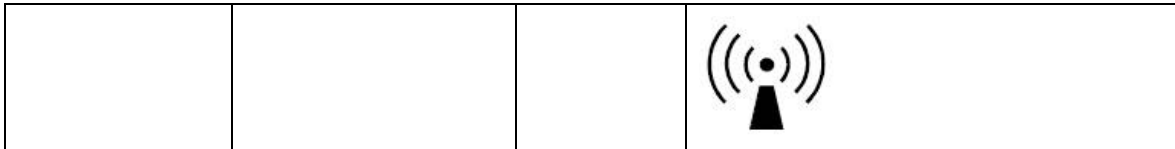

Caution



1. At 80 MHz and 900 MHz, the higher frequency range applies.
- 2 These guidelines may not apply in all situations. Electromagnetic propagation is affected by absorption and reflection from structures, objects and people.
 - ^a Field strengths from fixed transmitters, such as base stations for radio (cellular/cordless) telephones and land mobile radios, amateur radio, AM and FM radio broadcast and TV broadcast cannot be predicted theoretically with accuracy. To assess the electromagnetic environment due to fixed RF transmitters, an electromagnetic site survey should be considered. If the measured field strength in the location in which the FT-700 (R/L) is used exceeds the applicable RF compliance level above, the FT-700 (R/L) should be observed to verify normal operation. If abnormal performance is observed, additional measures may be necessary, such as reorienting or relocating the FT-700 (R/L).
 - ^b Over the frequency range 150 kHz to 80 MHz, field strengths should be less than 3 V/m.

4) Recommended separation distances between portable and mobile RF communications equipment and the FT-700 (R/L)

The FT-700 (R/L) is intended for use in an electromagnetic environment in which radiated RF disturbances are controlled. The customer or the user of the FT-700 (R/L) can help prevent electromagnetic interference by maintaining a minimum distance between portable and mobile RF communications equipment (transmitters) and the FT-700 (R/L) as recommended below, according to the maximum output power of the communications equipment.

Rated maximum output power of transmitter W	Separation distance according to frequency of transmitter m		
	150 kHz to 80 MHz $d = 1.2\sqrt{P}$	80 MHz to 900 MHz $d = 1.2\sqrt{P}$	900 MHz to 2,5 GHz $d = 1.2\sqrt{P}$
0.01	0.12	0.12	0.23
0.1	0.38	0.38	0.73
1	1.2	1.2	2.3
10	3.8	3.8	7.3
100	12	12	23

For transmitters rated at a maximum output power not listed above, the recommended separation distance *d* in meters (m) can be estimated using the equation applicable to the

frequency of the transmitter, where P is the maximum output power rating of the transmitter in watts (W) according to the transmitter manufacturer.

Caution



1. At 80 MHz and 900 MHz, the separation distance for the higher frequency range applies.
2. These guidelines may not apply in all situations. Electromagnetic propagation is affected by absorption and reflection from structures, objects and people.

TERMS OF EACH PART AND FUNCTIONS

1. FRONT PART

① START BUTTON

Press START button after being ready to measure, the cuff will be wrapped automatically and begins to pressurize.

② STOP BUTTON

Press STOP button if you want to stop it during measurement. Pressurizing will stop and the air will exhaust from the cuff.

③ LCD DISPLAY

It displays letters and animations during test processes, along with the result (systolic/ diastolic blood pressure, pulse, pulse wave pattern, blood pressure assessment) upon finishing examination.

④ CLOCK SECTION (Date and Time)

On the right upper corner of the LCD screen, date and time are displayed.

⑤ PRINTER COVER

It protects the printer.

⑥ AUTOMATIC CUTTER (printing paper let-out slot)

Printing paper is automatically cut off when it comes out through the slot.

⑦ CUFF

It wraps and releases the arm automatically for measurement.

⑧ ARM REST

When the arm is placed on the cuff, the arm supporter sustains the arm and makes the right position.

⑨ HUMAN SENSOR (option)

When a user approaches, power is automatically turned on and vice versa.

⑩ CARD-READER (option)

When card is swiped, it reads information in it and stores the measured results.

⑪ EMERGENCY STOP BUTTON

When your arm is oppressed due to high pressurizing or irregular operation is done, press this button then the cuff will be exhausted rapidly.

Note



The cuff and the buttons (START and STOP button) of this device are located at reverse side by R and L type.

FRONT PART

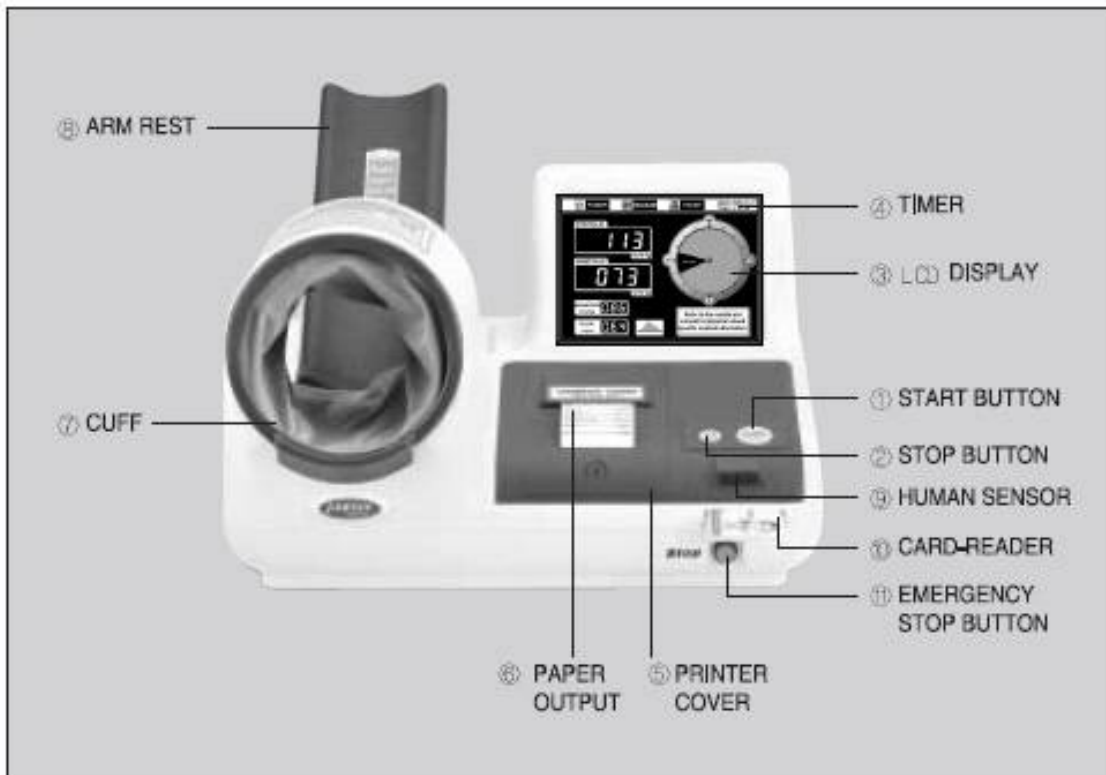

Note

Printer, card reader and human sensor are optional.

ID card can be issued either by the machine manager or by the manufacturer of the model.

The card stores six previous measured results and can contain seven measured results with the current one altogether.

When the model manager writes the card, please refer to the manual and specifications for operation and programs attached to the card writing device at purchase.



2. PRINTER

① PRINT button

- Use it when you print out the data.
- If you set [ON] at the rear (PRINT ON/OFF switch), the data is printed automatically even when you do not press PRINT button.
- Normally, when you press this button, all the data output after you turn the power on will be printed. (If you turn it off, all memorized data would be deleted.)
- When you set the date and time, the number goes up with this button pressed.

② FEED button

- Use this button for setting the paper
- When you set the date and time, the number goes down with this button pressed.

③ SET button

- Set the date and time
- The functions are as follows when pressing this before or after measurement.
(It does not work during measurement)
- Sequence is HOUR → MIN. → MON. → DAY → YEAR
- Within 5seconds, Setting of the date and time finished.
- See the page '15' for detailed method

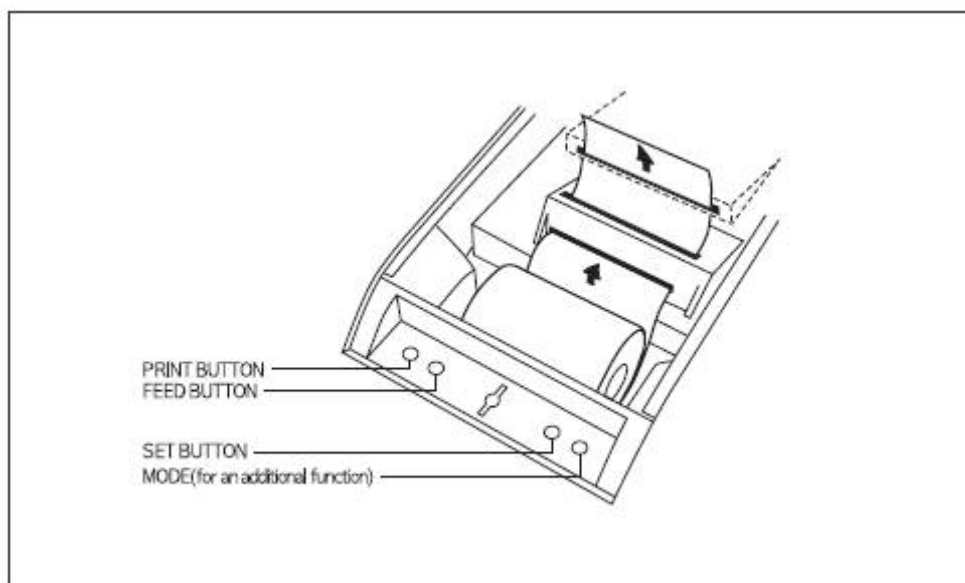

3. REAR PART

① POWER

It is used to turn the power on and off.

② AC INPUT

It is used to connect with the power code.

③ FUSE

Two (250V/1.6AL) fuses are installed to prevent overload.

④ CAL

This is only for inspection. Never open it.

⑤ EARTH (POTENTIAL EQUALIZATION TERMINAL)

Please make sure for safety.

⑥ COMMUNICATION PORTS (RS-232C)

It is for connecting between the main body and a computer or other equipment with cable (RS-232C) to transfer the data collected or measured.

And it is for connecting between the main body and the coin slot with RS-232C cable to transfer the data, too.

⑦ SENSOR ON/OFF

Human sensor is switched on and off.

⑧ SOUND ON/OFF

Music and voice output functions are activated with the switch [ON], and vice versa.

⑨ CARD ON/OFF

ID card is usable when the switch [ON], and vice versa.

⑩ PRINT ON/OFF

Measured results are printed out when switched [ON], and vice versa.

⑪ VOLUME (ANNOUNCE ON/OFF)

It controls volume output when switch is on while all volume is [OFF].

⑫ INFORMATION BOARD FIXER

Fix the information board here.

Note



1. While sound switch is activated on (so sound is functioning), place the VOLUME ON/OFF switch to [OFF] for deactivation of voice message and music play.
2. Printer, card reader, human sensor and reverse monitor is optional.

Note



The operator shall not contact the parts (SIP/SOP) and the patient simultaneously and "SIP/SOP shall be available to operator only"

REAR PART

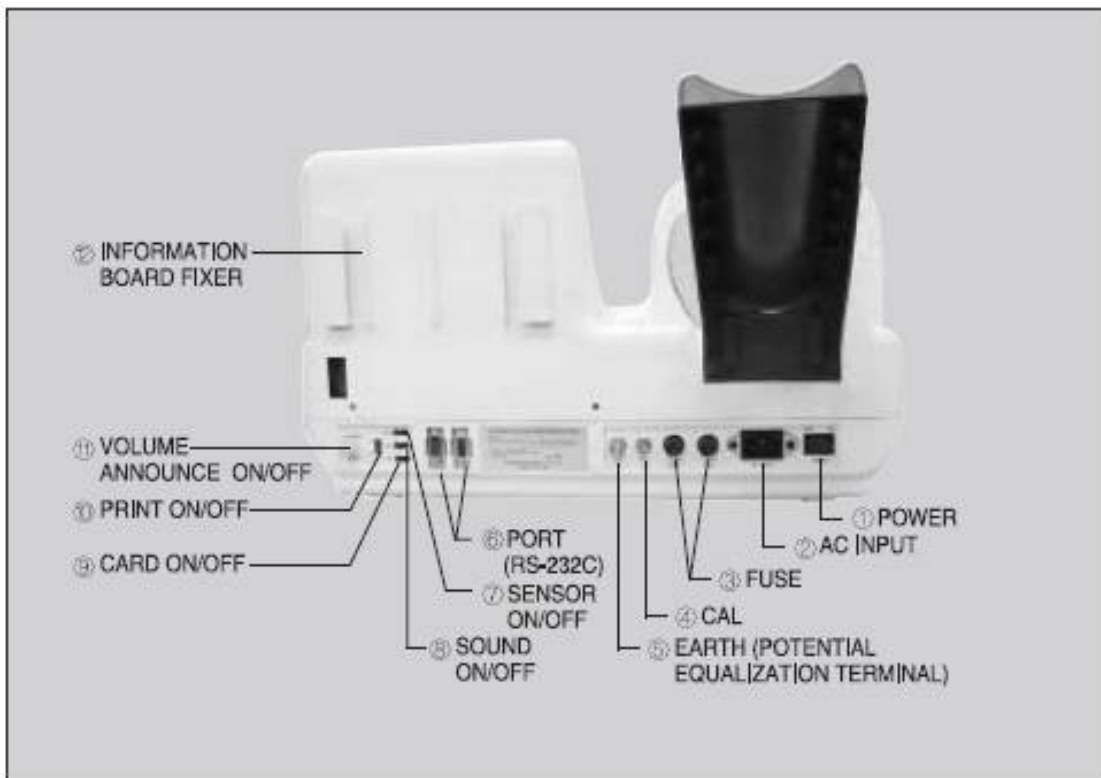

4. ACCESSORIES

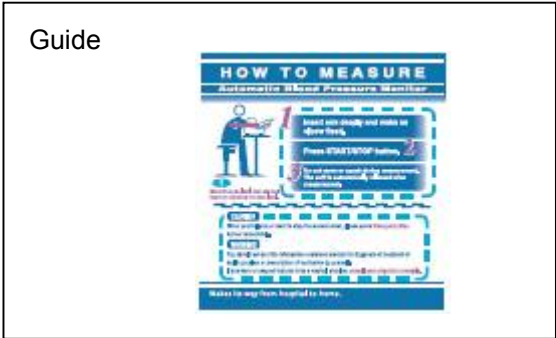
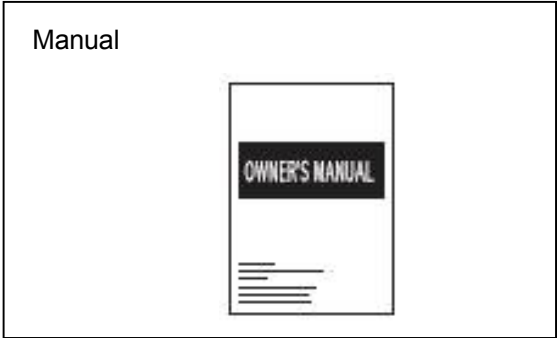
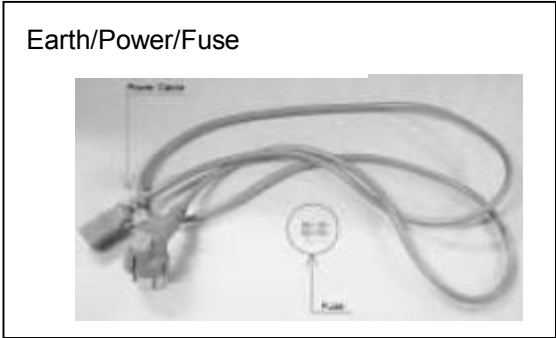

5. OPTIONS

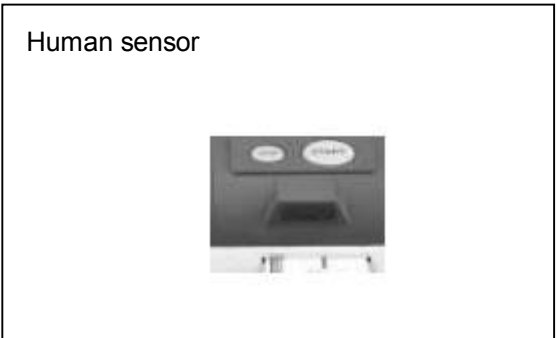
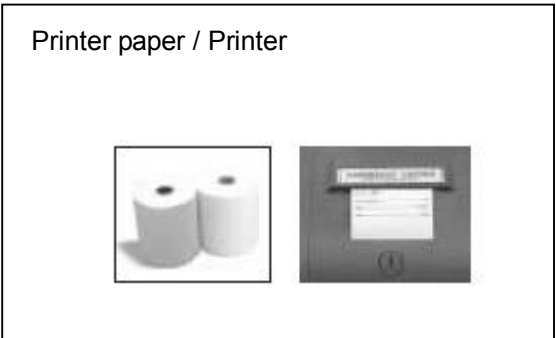
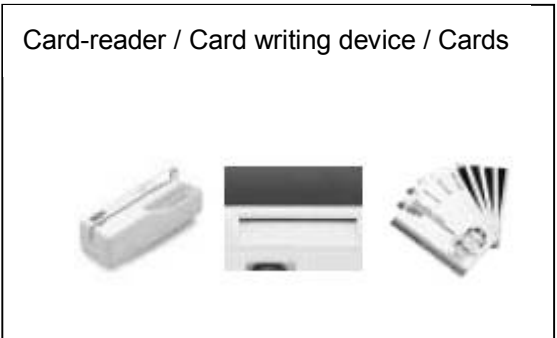

INSTALLATION

1. CONNECTING POWER CABLE

Just connect the power cable to the AC INPUT slot on the rear and turn the POWER ON/OFF switch (O/I) on the lower part of the rear (See the picture).

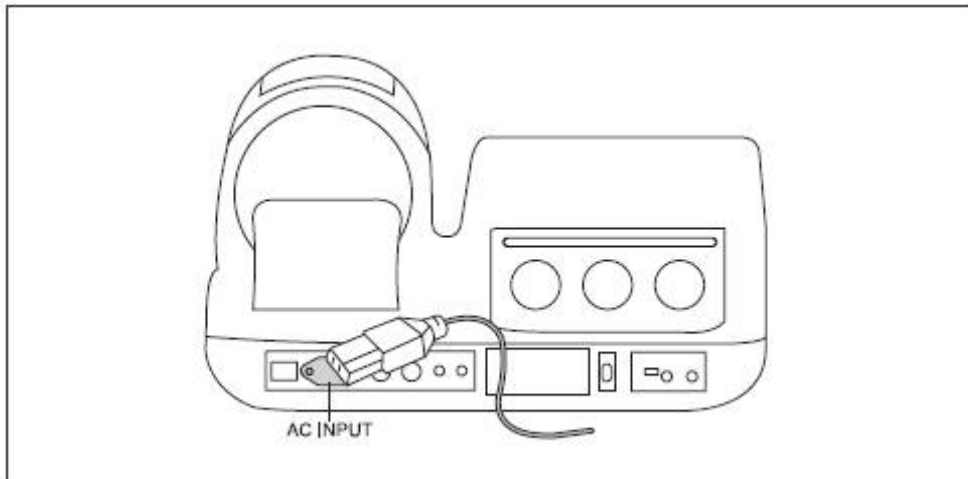

2. ASSEMBLING OF ARM SUPPORTER

The arm supporter consists of two parts. The first part (1) is attached to the main body when it is manufactured in the factory while the second part (2) is assembled to the first part as shown in the picture.

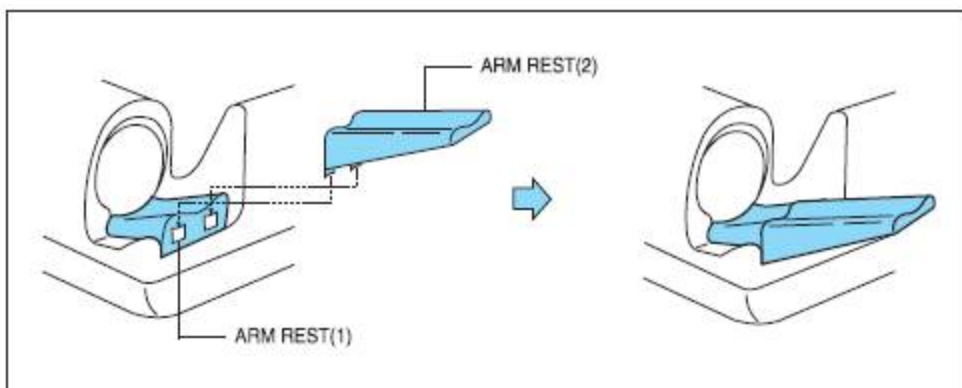

3. LOADING THE PRINT PAPER

- ① Check and see if power is turned on.
- ② Turn the nut (with a driver on the groove in the middle) on the lower printer cover clockwise to 90 degrees and open the cover.
- ③ Load the print paper as shown in the picture.
- ④ Insert the paper edge deep under the black roll, then it comes out above the CUTTER.
- ⑤ Balance the paper in the right place.
- ⑥ Cut the paper by pressing the FEED button.
- ⑦ Close the cover and turn the nut counterclockwise back.

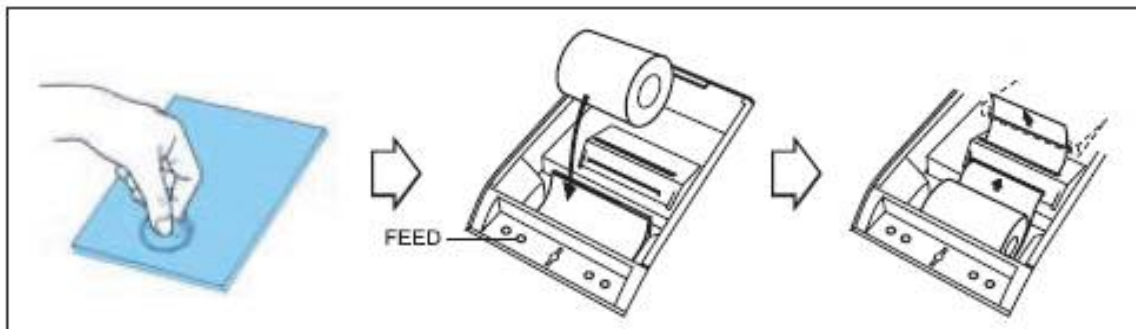

Note



Being thermal type, printing is photocopied on one side of the paper (slippery side), without using printing ink.

Please check remainder of the paper always and then replace it.

Please use exclusive paper (58mm).

Keep paper rolls in a dark and ventilated place.

Avoid any dust on the paper.

Do not pull the paper during printing. It could cause jam.

When printing paper is not loaded in correct place, it may cause the malfunction of the printer or paper will be shoved out.

After the exchange of paper to the printer cover does not close properly, the alarm sounds, LCD on the 'Err' is displayed. Please check the status of the printer cover.

4. CONNECTING PORT

To transmit the data, connect a computer or other external options to the unit.

Connect the USB cable both to port of the unit and to the computer jack or other external options. (See the picture)



5. SETTING TIME AND DATE

- Turn the power of the unit on.
- Open the printer cover.
- Sequence is HOUR → MINUTE → MONTH → DAY → YEAR

HOUR

Press SET button, then DATE and TIME will blink. At that time, press PRINT button. Its counts that have been measured since keeping button ON will be printed.

Press the SET button, DATE and TIME will appear up and down with the line between them at the right upper corner. At the same time, another line appears above the first two numbers in TIME column, and these numbers indicate the hour. The number goes up by pressing PRINT button and goes down by pressing FEED button.



MINUTE

After setting the hour, press the SET button again. The line appears above the second two numbers, and they indicate the minute. Adjust the minute as you did for the hour.

MONTH

After setting the minute, press the SET button again to see two numbers with the line above them in the DATE space, which indicates the month.

DAY

After setting the month, press the SET button again and there appears the number in the second column of DATE space with the line above the number.

YEAR

After the day is set, press the SET button once more for the year appearing in the third column of the DATE space with the line above the number.

The number gains when PRINT button is pressed and it reduces as FEED button is pressed.

Note

If you want to measure blood pressure during setting the date and time, press STOP button. Then you can measure again immediately.

Note

You should set all data at once (hour, minute, month, day and year).

In case of stopping setting, the values return to previous ones which you have done before.

The calendar and time functions work without plugging power cord in.

Calendar program is inputted for 100 years, and it would be adjusted automatically even at a leap year.

MEASUREMENT

1. CAUTIONS FOR MEASUREMENT

Take off heavy sweater or shirts.



Before measurement, take it easy and have a rest for a while.



Do not chat or move while you are being measured.



Do not measure in bad positions such as standing, half seat or sitting with your legs crossed.



When you fold your sleeves up, please make sure not to press your arm.



Put your arm deeply in order to fit to the arm rest.



If it is not easy to check your pulse with the stethoscope, the measurement cannot go on.



If you strain to your arm, there will be some differences. Please relax your arm and have a seat correctly.



2. MEASUREMENT

- ① Check the voltage and turn the power on.

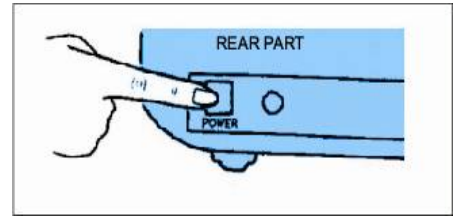

Note



With the human sensor attached optionally, the LCD screen is automatically turned on as it detects a user coming to the range.

The sensor should be placed [ON].

- ② For non-ID card users, a background music flows as power is turned on, and there appears the stand-by scene on the LCD screen.

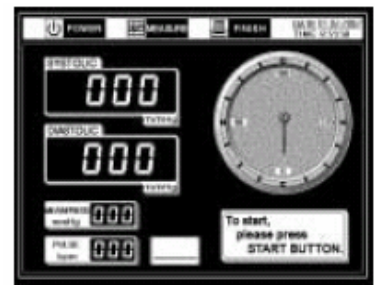

- ③ Please put either the right arm or left arm into the cuff.

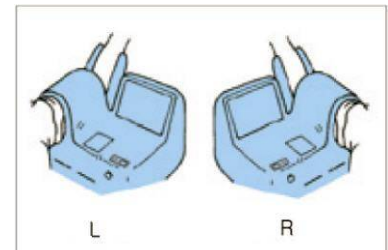

Note



An optimal arm circumference for this equipment is 9" to 14".

Caution



Place your arm on the arm supporter with the palm facing up through the cuff deeply. Adjust the height of the chair so that the arm is leveled off with the heart. When the arm is placed lower than the heart, blood pressure will become higher than actual value, and vice versa.



- ④ Press the START button.

Checking blood pressure begins as the cuff is automatically pressurized with the LCD screen displaying animations of the checking in process.

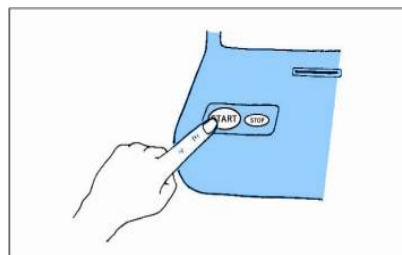

Caution



When the measurement is started, the voice message is announced as “Starting measurement, don’t move or speak please.” When you feel painful and want to stop the measurement, press EMERGENCY BUTTON.



- ⑤ The LCD screen displays the results of checking upon finishing along with a voice message of “Measurement completed, pull your arm out please. Thank you.”

The cuff will automatically release your arm and resume the original position.



Note



When the measurement is not satisfactory, the voice message comes out as “Cannot measure, we will try again.” At this time, let your arm stay into the cuff and start over again from the beginning.

- ⑥ The results are printed out, and a voice message also announces the results as “Your blood pressure is systolic 000, diastolic 000 and pulse 000.”
- ⑦ Pull your arm out from the cuff.
- ⑧ When you want to measure one more time, press STOP button and start all procedures from the beginning.

Note

When the PRINT ON/OFF switch on the rear is set as 「OFF」, the result will not be printed even if the measurement is completed.

Note

For the card users, six previous results stored in the card can be recalled to compare with the current ones newly checked.
Seven results altogether could be printed out.

Caution

This device is only for adult.

3. DATA ON MEASUREMENT BY PRINTER

▼ Results on Printing Paper

ID-NO0001
DATE02/03/2002
TIME06:04
SYSTOLIC124mmHg
DIASTOLIC084mmHg
MEANPRESS075mmHg
PULSE075bpm
P.R.P9300

▼ LCD Display



▼ Classification of the blood pressure

: National High Blood Pressure Education Program, National Heart, Lung and Blood institute, NIH (JNC7, 2003)

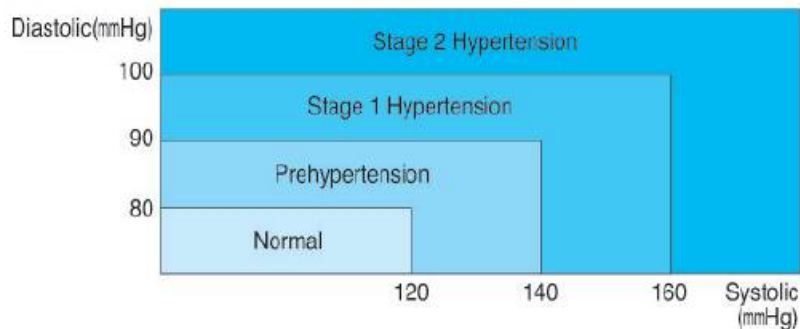

Note



- When pressure is high with the jammed air hose, message appears on the printer as ERROR PRESSURE.
When the message is repeated, call for maintenance service.
- When pressure is low as air leaks, message appears on the printer as ERROR CUFF.
When the message is repeated, call for maintenance service.
- When the subject moves or speaks while in testing, message appears on the printer as ERROR MEASURE.
Try to retest after a while. If the message is repeated, call for maintenance service.

MAINTENANCE

This unit is for 230V. If you want 110V, please contact to a service center.

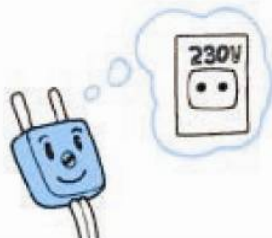

Remind the permitted current(60VA).



Do not disassemble the main body.



To prevent electric shock, please make sure the earth.

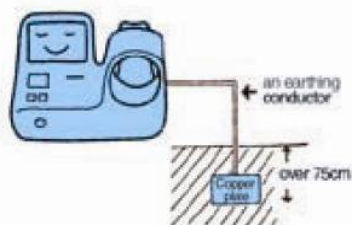

When grounded, do not mount it close to the gas pipe, water pipe, lightning rod and connection of telephone.



When you take out the plug, grasp the plug exactly.



Keep the unit dry and do not wet it. Never immerse the main unit in the water. It could cause damage the electronic parts inside.



Avoid direct sunshine, humidity, dust and extreme changes in temperature.



Do not put heavy things on the unit.

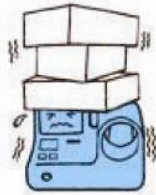

Wipe the unit with a damp cloth. Do not use benzine, alcohol or liquid similar to solvents and wet cloth.



Check the unit conditions occasionally.

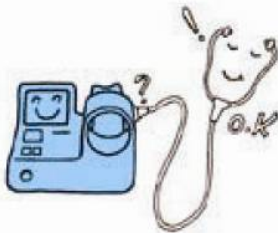

Do not use the unit under the condition of shock or vibration.



Do not install and shock with chemicals or gas.



When you re-use after a long time, please check the unit carefully.



When some problems are found, please call our service center.



ERROR & REPAIR

Error	Cause	Repair
ERROR PRESSURE	pressure is high with the jammed air hose	When the message is repeated, call for maintenance service.
ERROR CUFF	pressure is low as air leaks	When the message is repeated, call for maintenance service.
ERROR MEASURE	subject moves or speaks while in testing	<ul style="list-style-type: none">- Don't move or speak.- When the message is repeated, call for maintenance service.

AFTER SERVICE

1. AFTER SERVICE

- ! If there is any problem with the unit, please follow the steps below;
 - ※ Contact our company's Overseas Service Department immediately.
After gathering the model name, Serial Number, date of purchase and description of the problem, contact our company with information shown below.
 - ※ Try to solve the problem over the phone with the personnel of local service department.
If the problem cannot be solved over the phone, just return to service department directly.
 - ※ Our company or local distributor will make available on-request circuit diagrams, component part list, descriptions, calibration or other information which will assist your appropriately qualified technical personnel to repair those parts of unit which are designated by our company as repairable.

How to contact our company

Write us at:

JAWON MEDICAL CO., LTD

29, Gongdan 4-ro, Jillyang-eup, Gyeongsan-si, Gyeongsangbuk-do, Korea

TEL : 82-53-856-0993

FAX L 82-53-856-0995

(You can also contact the following representative or your local distributor)

2. PACKING AND TRANSPORT

Our company follows his packing ways to protect any impact during transporting etc. So please do not transport or move the unit without our company's packing condition as your wishes.

The normal storage environment; -20°C~ 60°C of temperature, Humidity is less than 95% non-condensing.

SPECIFICATION

Model	FT-700 (R)	FT-700 (L)
Measuring Method	Oscillometric	
Display mode	LCD display	
Result Contents	Systolic/Diastolic/Mean blood pressure, Pulse, P.R.P.	
Measuring ranges	Pressure 30~300mmHg, Pulse 30~200beats/minute	
Accuracy	Pressure ± 2 mmHg, Pulse $\pm 5\%$	
Resolving Power	1mmHg	
Pressurizing method	DC Motor	
Cuff type	Belt type	
Pressurizing time	Approx. 10 seconds	
Measuring time	Approx. 33 seconds	
Printer	Thermal printer (optional)	
Power supply	AC 230V, 50/60Hz	
Power consumption	40VA	
Operation ambient	Temperature 10~40℃, Humidity 30~75%	
Storage ambient	Temperature -20~60℃, Humidity Less than 95%	
Data transmission	RS-232C	
Dimension	480(W) × 310(D) × 290(H) mm	
Weight	Approx. 11kg	
Measuring parts	FT-700 (R): Right arm	FT-700 (L): Left arm

WARRANTY

WARRANTY

Item	Automatic Blood Pressure Monitor	Warranty period
Model	FT-700 (R/L)	1year (main unit only)
Serial NO.		

Date of purchase	Month	Day	Year
Customer	Name:		TEL:
	Address:		
Dealer	Name:		TEL:
	Address:		

Date	Defection	Confirmation

Note



- When you receive this warranty, make sure that the name of the dealer and the month, day and year of purchase are all completed.
- This warranty will not be reissued, please keep it in a safe place.

Periodic Check List

Management No. _____

Item		Inspection Subject	Requirements	Judgement	Remarks
Visual Check					
Mainframe	1	Enclosure	No scratch, crack, deformation and rust	Pass/Fail	
	2	Labels and panels	No peeling and dust	Pass/Fail	
	3	Keys	No damage	Pass/Fail	
	4	Cuffs	No scratch and damage	Pass/Fail	
Accessories	1	Power cord	No scratch and damage	Pass/Fail	
	2	User manual	Kept in proper place	Pass/Fail	
Mechanical Check					
Mainframe	1	Keys	Smooth operation	Pass/Fail	
	2	Recorder	Smooth operation with no abnormal sound	Pass/Fail	
	3	Cuffs	Smooth operation	Pass/Fail	
Accessories	1	Power cord	Smooth operation and removal	Pass/Fail	
Electrical Check					
Performance	1	Power supply	Screen display upon power-on	Pass/Fail	
	2	Display	No abnormality and flickering	Pass/Fail	
	3	Printing	printing possible	Pass/Fail	
	4	Measurement	Proper measurement	Pass/Fail	
General Judgement				Pass/Fail	
Model		FT-700 (R/L)		Serial No.	
Installation place				Date of purchase	
Check date		Checked by		Approved by	

Copy this sheet for use

If repair is required, write down so in the Remarks column.

Daily Check List

Management No. _____

Item		Inspection Subject	Requirements	Judgement	Remarks
Visual Check					
Mainframe	1	Enclosure	No scratch, crack, deformation and rust	Pass/Fail	
	2	Labels and panels	No peeling and dust	Pass/Fail	
	3	Keys	No damage	Pass/Fail	
	4	Cuffs	No scratch and damage	Pass/Fail	
Accessories	1	Power cord	No scratch and damage	Pass/Fail	
	2	User manual	Kept in proper place	Pass/Fail	
Mechanical Check					
Mainframe	1	Keys	Smooth operation	Pass/Fail	
	2	Recorder	Smooth operation with no abnormal sound	Pass/Fail	
Accessories	1	Power cord	Smooth operation and removal	Pass/Fail	
Electrical Check					
Performance	1	Power supply	Screen display upon power-on	Pass/Fail	
	2	Display	No abnormality and flickering	Pass/Fail	
	3	Printing	Waveform printing possible	Pass/Fail	
	4	Measurement	Proper measurement	Pass/Fail	
Other	1	Clock	Present date/time	Pass/Fail	
General Judgement				Pass/Fail	
Model		FT-700 (R/L)		Serial No.	
Installation place			Date of purchase		
Check date		Checked by		Approved by	

Copy this sheet for use

If repair is required, write down so in the Remarks column.



If the problems continue, call the service center. When you ask for service, the manufacturer's label, serial number, date of original purchase and explanation of malfunction will be required.

※ For purpose of improvement, specifications and subject to change without notice.



HEAD OFFICE: 29, Gongdan 4-ro, Jillyang-eup, Gyeongsan-si,
Gyeongsangbuk-do, 38470, Republic of Korea
TEL: 82-53-856-0993, FAX: 82-53-856-0995

EUROPEAN REPRESENTATIVE:

VITAKO Sp. z o.o.

UL. MALEJ SYRENKI 2 71-790 SZCZECIN, POLAND

TEL: 91 8522900 / 901, FAX: 91 8522910