

apornorm[®]
die marke der apotheke

Gebrauchsanweisung

Oberarm **PROFESSIONELL**

Clinically TESTED
BHS A/A-
BHS Protocol

BENUTZER

Klinisch VALIDIERT

5 Jahre GARANTIE



**Erkennt Vorhofflimmern -
die häufigste Ursache
für Schlaganfall**

Mit automatischer
Mehrfachmessung



DE
2



EN
14



TR
26



RU
38

technology by
microlife

aponorm® Professionell – Kurzanleitung

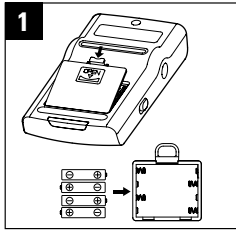

Legen Sie die mitgelieferten Batterien ein.

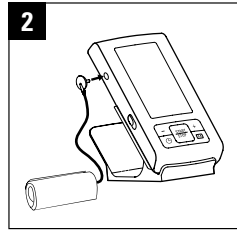

Schließen Sie die Manschette an.

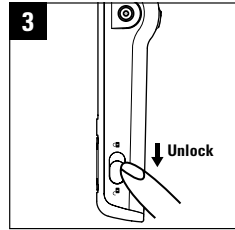

Entriegeln Sie das Gerät, indem Sie den Schalter an der Seite nach unten schieben.

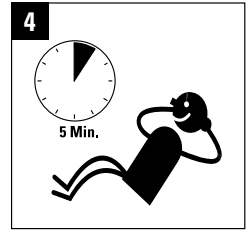

Vor jeder Messung sollten Sie einige Minuten entspannen.

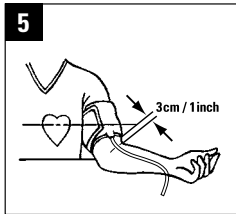

Legen Sie die Manschette so an, dass sie ca. 3 cm oberhalb der Armbeuge sitzt. Lagern Sie den Arm ausgestreckt, so dass die Manschette sich in Brusthöhe befindet.

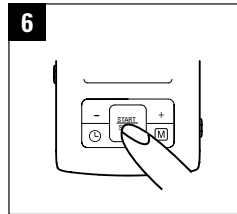

Starten Sie die Messung mit einem Druck auf Start/Stop.

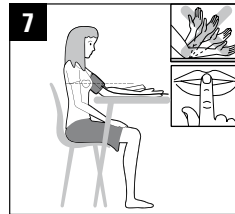

Während der Messung, weder sprechen, bewegen, essen, trinken oder rauchen.

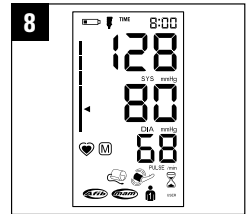

Nach der Messung erscheinen auf dem Display die gemessenen Blutdruckwerte.

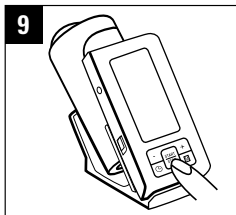

Schalten Sie das Gerät aus. Messungen werden automatisch gespeichert.

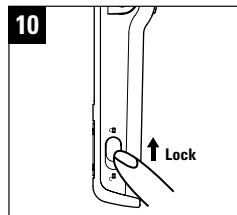

Sie können das Gerät wieder verriegeln, in dem Sie den Schalter nach oben schieben.

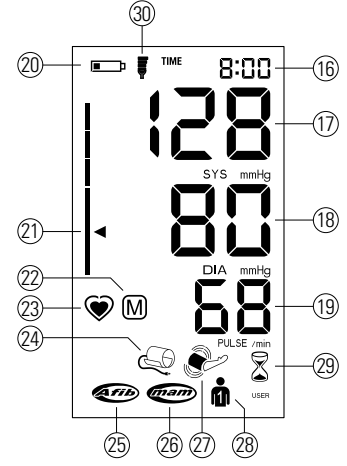
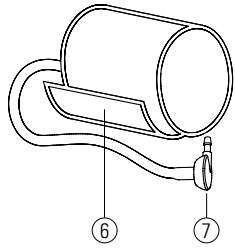
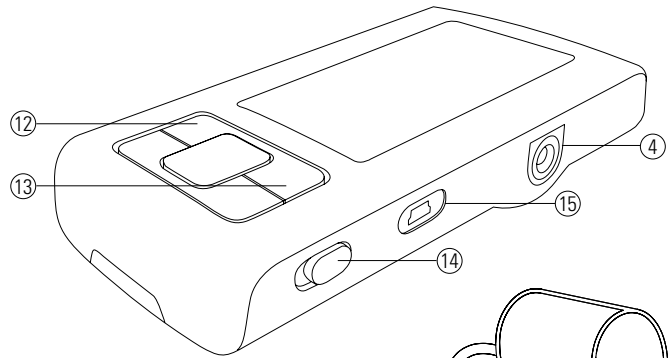
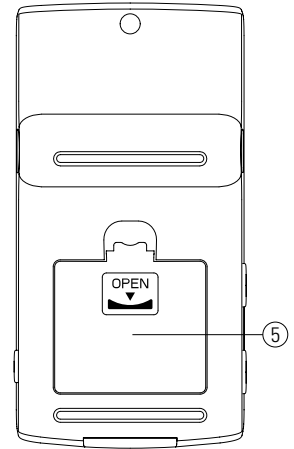
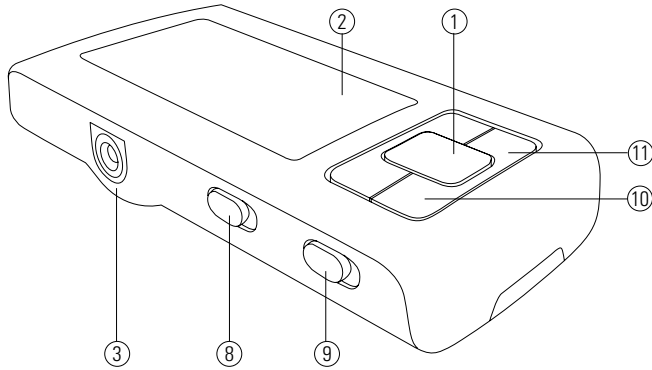

- ① START/STOP Button
- ② Display
- ③ Cuff Socket
- ④ Mains Adapter Socket
- ⑤ Battery Compartment
- ⑥ Cuff
- ⑦ Cuff Connector
- ⑧ AFIB/MAM Switch
- ⑨ User Switch
- ⑩ Time Button
- ⑪ M-Button (Memory)
- ⑫ - «Backward» Button
- ⑬ + «Forward» Button
- ⑭ Lock Switch
- ⑮ USB Port

Display

- ⑯ Date/Time
- ⑰ Systolic Value
- ⑱ Diastolic Value
- ⑲ Pulse Rate
- ⑳ Battery Display
- ㉑ Traffic Light Display
- ㉒ Stored Value
- ㉓ Pulse Indicator
- ㉔ Cuff Check Indicator
- ㉕ Atrial Fibrillation Indicator (AFIB)
- ㉖ AFIB/MAM Mode
- ㉗ Arm Movement Indicator
- ㉘ User Indicator
- ㉙ MAM Interval Time
- ㉚ Radio Clock



Type BF applied part

Dear Customer,

Your new **aponorm®** by microlife blood pressure monitor is a reliable medical device for taking measurements on the upper arm. It is simple to use, accurate and comes highly recommended for blood pressure monitoring in your home. This device was developed in collaboration with physicians and clinical tests carried out proving its measurement accuracy to be of a very high standard.*

aponorm® by microlife AFIB detection is the world's leading digital blood pressure measurement technology for the detection of atrial fibrillation (AFIB) and hypertension. These are the two top risk factors of getting a stroke or heart disease in the future. It is important to detect AFIB and hypertension at an early stage, even though you may not experience any symptoms. Appropriate treatment will reduce your risk of suffering a stroke. For this reason, it is recommended that you visit your doctor when the device gives an AFIB signal during your blood pressure measurement. The AFIB algorithm of **aponorm®** by microlife has been clinically investigated by several prominent clinical investigators and showed that the device detects patients with AFIB at a certainty of 97-100%. ^{1,2}



Read the instructions carefully before using this device.

Table of Contents

Please read through these instructions carefully so that you understand all functions and safety information. We want you to be happy with your **aponorm**® by microlife product. If you have any questions, problems or want to order spare parts please contact **aponorm**® by microlife-Customer Service. Your dealer or pharmacy will be able to give you the address of the **aponorm**® by microlife dealer in your country. Alternatively, visit the internet at www.aponorm.de where you will find a wealth of invaluable information on our products.

Stay healthy – **aponorm**® by microlife!

* *This device uses the same measuring technology as the award winning «BP 3BTO-A» model tested according to the British Hypertension Society (BHS) protocol.*

¹ *Stergiou GS, Karpettas N, Protogerou A, Nasothimiou EG, & Kyriakidis M. Diagnostic accuracy of a home blood pressure monitor to detect atrial fibrillation. J Hum Hyperten 2009; 1-5.*

² *Wiesel J, Fitzig L, Herschman Y, & Messineo FC Detection of Atrial Fibrillation Using a Modified Microlife Blood Pressure Monitor. Am J Hypertens 2009; 848-852.*

1. Important Facts about Blood Pressure and Self-Measurement

- How do I evaluate my blood pressure?

2. Important Facts about Atrial Fibrillation (AFIB)

- What is Atrial Fibrillation (AFIB)?
- How does AFIB impact my family or me?
- Microlife AFIB detection provides a convenient way to screen for AFIB (only in AFIB/MAM mode)
- Risk factors you can control

3. Using the Device for the First Time

- Inserting the batteries
- Setting the date and time
- Selecting the correct cuff
- Selecting the user
- Select the measuring mode: standard or AFIB/MAM mode
- AFIB/MAM mode (highly recommended)

4. Taking a Blood Pressure Measurement using this Device

- How not to store a reading

5. Appearance of the Atrial Fibrillation Indicator for early Detection (only in AFIB/MAM mode)

6. Traffic Light Indicator in the Display

7. PC-Link Functions

- Installation and data transmission

8. Data Memory

- Viewing the stored values
- Memory full
- Clearing all values

9. Battery Indicator and Battery change

- Low battery
- Flat battery – replacement
- Which batteries and which procedure?
- Using rechargeable batteries

10. Using a Mains Adapter

11. Error Messages

12. Safety, Care, Accuracy Test and Disposal

- Safety and protection
- Device care
- Cleaning the cuff
- Accuracy test
- Disposal

13. Guarantee

14. Technical Specifications

Guarantee Card

1. Important Facts about Blood Pressure and Self-Measurement

- **Blood pressure** is the pressure of the blood flowing in the arteries generated by the pumping of the heart. Two values, the **systolic** (upper) value and the **diastolic** (lower) value, are always measured.
- The device indicates the **pulse rate** (the number of times the heart beats in a minute).
- **Permanently high blood pressure values can damage your health and must be treated by your doctor!**
- Always discuss your values with your doctor and tell him/her if you have noticed anything unusual or feel unsure. **Never rely on single blood pressure readings.**
- There are several causes of excessively high blood pressure values. Your doctor will explain them in more detail and offer treatment where appropriate. Besides medication, weight loss and exercise can also lower your blood pressure.
- **Under no circumstances should you alter the dosages of any drugs prescribed by your doctor!**
- Depending on physical exertion and condition, blood pressure is subject to wide fluctuations as the day progresses. **You should therefore take your measurements in the same quiet conditions and when you feel relaxed!** Take at least two readings every time (in the morning and in the evening) and average the measurements.
- It is quite normal for two measurements taken in quick succession to produce significantly **different results**. Therefore we recommend to use the MAM technology.
- **Deviations** between measurements taken by your doctor or in the pharmacy and those taken at home are quite normal, as these situations are completely different.
- **Several measurements** provide much more reliable information about your blood pressure than just one single measurement.

- **Leave a small break** of at least 15 seconds between two measurements.
- If you suffer from an **irregular heartbeat**, measurements taken with this device should be evaluated with your doctor.
- **The pulse display is not suitable for checking the frequency of heart pacemakers!**
- If you are **pregnant**, you should monitor your blood pressure very closely as it can change drastically during this time!

☞ This monitor is specially tested for use in pregnancy and preeclampsia. When you detect unusual high readings in pregnancy, you should measure again after 4 hours. If the reading is still too high, consult your doctor or gynaecologist.

How do I evaluate my blood pressure?

Table for classifying home blood pressure values in adults in accordance with the international Guidelines (ESH, AHA, JSH). Data in mmHg.

Range	Systolic	Diastolic	Recommendation
blood pressure too low	↓ 100	↓ 60	Consult your doctor
1. blood pressure optimum	100 - 130	60 - 80	Self-check
2. blood pressure elevated	130 - 135	80 - 85	Self-check
3. blood pressure too high	135 - 160	85 - 100	Seek medical advice
4. blood pressure dangerously high	160 ↑	100 ↑	Urgently seek medical advice!

The higher value is the one that determines the evaluation. Example: a blood pressure value of **140/80** mmHg or a value of **130/90** mmHg indicates «blood pressure too high».

2. Important Facts about Atrial Fibrillation (AFIB)

What is Atrial Fibrillation (AFIB)?

Normally, your heart contracts and relaxes to a regular beat. Certain cells in your heart produce electrical signals that cause the heart to contract and pump blood. Atrial fibrillation occurs when rapid, disorganized electrical signals are present in the heart's two upper chambers, called the atria; causing them to contract irregularly (this is called fibrillation). Atrial fibrillation is the most common form of heart arrhythmia or irregular heart beat. It often causes no symptoms, yet it significantly increases your risk of stroke. You'll need a doctor to help you control the problem.

How does AFIB impact my family or me?

People with AFIB have a five-fold higher risk of getting stroke. Since the chance of having a stroke increases with age, individuals above the age of 55 years benefit most from screening for AFIB.

However, for younger individuals with risk factors such as diabetes or hypertension screening for AFIB is also recommended. Early diagnosis of AFIB followed by adequate treatment can significantly reduce the risk of getting stroke. Younger individuals with AFIB have a relatively low risk of getting stroke as compared to elder people.

apnorm® by microlife AFIB detection provides a convenient way to screen for AFIB (only in AFIB/MAM mode)

Knowing your blood pressure and knowing whether you or your family members have AFIB can help reduce the risk of stroke. **apnorm®** by microlife AFIB detection provides a convenient way to screen for AFIB whilst taking your blood pressure.

Risk factors you can control

High blood pressure and AFIB are both considered «controllable» risk factors for strokes. Knowing your blood pressure and knowing whether you have AFIB is the first step in proactive stroke prevention.

3. Using the Device for the First Time

Inserting the batteries

After you have unpacked your device, first insert the batteries. The battery compartment ⑤ is on the bottom of the device. Insert the batteries (4 x size AAA 1,5 V), thereby observing the indicated polarity. Switch the Lock Switch ⑭ to «unlock» position.

Setting the date and time

Your **aponorm**® Professionell upper arm blood pressure monitor is equipped with a radio clock, which is controlled by the DCF77 signal. This time and date are set automatically. If no DCF77 signal (this is the term for the time signal transmitter) is available, the time is not adjusted automatically.

The display comes to receiving mode and device sets the time automatically, after insert batteries.

☞ If you do not wish to set the time or you want to take a measurement immediately, exit the time setting mode by pressing the Start/Stop button ①.

Once the time signal is received, the radio clock icon ⑳ flashes on the display every second until the reception of the DCF77 signal is complete.

While receiving the DCF77 signal, the radio clock icon ⑳ flashes first with 1, then 2 and then 3 bars above it. When the icon appears with 3 bars, the time has been set. First the date and then the time are displayed at the top right of the display. Then the time is displayed permanently together with the radio clock icon ⑳.

☞ The automatic setting of date and time takes about 2-4 minutes. If no signal is received within 10 minutes, „-: - -” appears on the display.

Now you need to improve the reception by choosing another location or set the clock manually (for more information see „manual setting”). After a change of location, batteries have to be re-inserted or to reset radio clock to „ON” to restart the auto setting again.

Manual setting

(if automatic setting does not work or is not desired):

The device must be in ON mode. If you do not press any buttons for 1 minute during the time setting, the time setting mode switches off and „-: - -” appears in the clock display.

1. Press down Time button several seconds until „bl OFF” appears on the display.
2. Press Time button again, the radio clock indicator and „ON” appears in the display.
3. Press the M button to switch on („ON”) or switch off the radio clock („OFF”).
4. Press ON/OFF button to confirm and return to standby mode, or if the radio clock is switched off, you can press Time button to confirm (continue with step 1).
5. The year number flashes in the display. You can set the year by pressing either the «+» ⑬ or the «-» ⑫ button. To confirm and then set the month, press the time button ⑩.
6. Press the «+» ⑬ or the «-» ⑫ button to set the month. Press the time button ⑩ to confirm and then set the day.
7. Follow the instructions above to set the day, hour and minutes.
8. Once you have set the minutes and pressed the time button, the date and time are set and the time is displayed.
9. If you want to change the date and time, press and hold the time button down for approx. 3 seconds until the year number starts to flash. Now you can enter the new values as described above.

Selecting the correct cuff

aponorm[®] by microlife offers different cuff sizes. Select the cuff size to match the circumference of your upper arms (measured by close fitting in the centre of the upper arm).

Cuff size	for circumference of upper arm
S	17 - 22 cm
M	22 - 32 cm
M - L	22 - 42 cm
L - XL	32 - 52 cm

☞ Only use **aponorm**[®] by microlife cuffs.

- ▶ Connect the cuff to the device by inserting the cuff connector ⑦ into the cuff socket ③ as far as it will go.

Selecting the user

This device allows to store the results for 2 individual users.

- ▶ **Before each measurement**, set the user switch ⑨ for the intended user: user 1 or user 2.
- ▶ User 1: slide the user switch ⑨ upwards to the user 1 icon.
- ▶ User 2: slide the user switch ⑨ downwards to the user 2 icon.
- ▶ The first person to measure should select user 1.

Select the measuring mode: standard or AFIB/MAM mode

This device enables you to select either standard (standard single measurement) or AFIB/MAM mode (automatic triple measurement).

To select standard mode, slide the AFIB/MAM switch ⑩ on the side of the device downwards to position «1» and to select AFIB/MAM mode, slide this switch upwards to position «3».



AFIB/MAM mode (highly recommended)



In AFIB/MAM mode, 3 measurements are automatically taken in succession and the result is then automatically analysed and displayed. Because blood pressure constantly fluctuates, a result determined in this way is more reliable than one produced by a single measurement. AFIB detection is only activated in AFIB/MAM mode.

- After pressing the START/STOP button ①, the selected AFIB/MAM mode appears in the display as the MAM-symbol ⑥.
- The bottom, right hand section of the display shows a 1, 2 or 3 to indicate which of the 3 measurements is currently being taken.
- There is a break of 15 seconds between the measurements (15 seconds are adequate according to «Blood Pressure Monitoring, 2001, 6:145-147» for oscillometric instruments). A count down indicates the remaining time.
- The individual results are not displayed. Your blood pressure will only be displayed after all 3 measurements are taken.
- Do not remove the cuff between measurements.
- If one of the individual measurements was questionable, a fourth one is automatically taken.



4. Taking a Blood Pressure Measurement using this Device

Checklist for taking a reliable measurement

1. Avoid activity, eating or smoking immediately before the measurement.
2. Sit down for at least 5 minutes before the measurement and relax.
3. **Always measure on the same arm** (normally left).
It is recommended that doctors perform double arm measurements on a patient's first visit in order to determine which arm to measure in the future. The arm with the higher blood pressure should be measured.
4. Remove close-fitting garments from the upper arm. To avoid constriction, shirt sleeves should not be rolled up – they do not interfere with the cuff if they are laid flat.
5. Always ensure that the correct cuff size is used (marking on the cuff).
 - Fit the cuff closely, but not too tight.
 - Make sure that the cuff is positioned 2 cm above the elbow.
 - The **artery mark** located on the cuff (ca. 3 cm long bar) must lie over the artery which runs down the inner side of the arm.
 - Support your arm so it is relaxed.
 - Ensure that the cuff is at the same height as your heart.
6. Slide the lock switch  down to the «unlock» position. Press the START/STOP button  to start measuring.
7. The cuff will now pump up automatically. Relax, do not move and do not tense your arm muscles until the measurement result is displayed. Breathe normally and do not talk.
8. When the correct pressure is reached, the pumping stops and the pressure falls gradually. If the required pressure was not reached, the device will automatically pump some more air into the cuff.
9. During the measurement, the pulse indicator  flashes in the display.

10. The result, comprising the systolic  and the diastolic  blood pressure and the pulse rate  is displayed. Note also the explanations on further display symbols in this booklet.
11. When the device has finished measuring, remove the cuff.
12. Switch off the device. (The monitor does switch off automatically after approx. 1 min.).

How not to store a reading

Press the START/STOP button  while the reading is being displayed. Keep the button pressed until «M»  is flashing and then release it. Confirm by pressing the M-button  again.

 You can stop the measurement at any time by pressing the START/STOP button (e.g. if you feel uneasy or an unpleasant pressure sensation).

5. Appearance of the Atrial Fibrillation Indicator for early Detection (only in AFIB/MAM mode)

This device is able to detect atrial fibrillation (AFIB). This symbol  indicates that atrial fibrillation was detected during the measurement.

If AFIB is present during blood pressure measurement, the AFIB indicator is displayed flashing at the end of the triple measurements.

It is highly recommended to take an additional AFIB/MAM measurement an hour later to confirm the result. If after repeated measurement the AFIB symbol is no longer displayed there is no cause for concern. In such case it is recommended to measure again the next day.



However, if the symbol appears on a regular basis (e.g. several times a week with measurements taken daily) we advise you to visit your doctor. Please provide the following explanation:

Information for the doctor on frequent appearance of the atrial fibrillation indicator

This device is an oscillometric blood pressure monitor that also analyses pulse irregularity during measurement. The device is clinically tested.

The AFIB symbol is displayed after the measurement, if atrial fibrillation occurred during measuring. If the symbol appears more frequently (e.g. several times per week on measurements performed daily) we recommend the patient to seek medical advice.

The device does not replace a cardiac examination, but serves to detect atrial fibrillation that often remains undiagnosed until stroke occurs.

-  Keep the arm still during measuring to avoid false readings.
-  This device may not detect atrial fibrillation in people with pacemakers or defibrillators.

6. Traffic Light Indicator in the Display

The bars on the left-hand edge of the traffic light display ① show you the range within which the indicated blood pressure value lies. Depending on the height of the bar, the readout value is either within the optimum (green), elevated (yellow), too high (orange) or dangerously high (red) range. The classification corresponds to the 4 ranges in the table as defined by the international guidelines (ESH, AHA, JSH), as described in «Section 1.».

7. PC-Link Functions

This device can be used in conjunction with a personal computer (PC) running the **aponorm®** by microlife Blood Pressure Analyser (BPA) software. The memory data can be transferred to the PC by connecting the monitor via a cable.

If no CD and cable is included download the BPA software from www.aponorm.de and use a USB cable with a Mini-B 5 pin connector.

Installation and data transmission

1. Insert CD into the CD ROM drive of your PC. The installation will start automatically. If not, please click on «SETUP.EXE».
2. Connect the monitor via the cable to the PC; there is no need to switch the device on. 3 horizontal bars will appear on the display and last for 3 seconds.
3. The bars will then flash to indicate that the connection between PC and device is successful. As long as the cable is plugged in, the bars will keep flashing and the buttons are disabled.
 -  During the connection, the device is completely controlled by the computer. Please refer to the «help» file for software instructions.

8. Data Memory

This device automatically stores up to 99 measurement values for each of the 2 users.

Viewing the stored values

Press the M-button ① briefly, when the device is switched on. The display first shows «M» ② and then an average value. The device then switches to the last stored value. Press the M-button again to exit the memory mode. Pressing the «+» ③ or the «-» ④ button repeatedly enables you to move from one stored value to another.

Memory full



Pay attention that the maximum memory capacity of 99 memories per user is not exceeded. **When the 99 memory is full, the oldest value is automatically overwritten with the 100th value.** Values should be evaluated by a doctor before the memory capacity is reached – otherwise data will be lost.

Clearing all values

1. Select either user 1 or 2 with the user switch ⑤, when the device is switched on.
 2. Hold down the M-button ① until «CL» appears and then release the button.
 3. Press the M-button while «CL» is flashing to permanently clear all values of the selected user.
- ☞ **Cancel deletion:** press START/STOP button ① while «CL» is flashing.
 - ☞ Individual values cannot be cleared.

9. Battery Indicator and Battery change

Low battery

When the batteries are approximately $\frac{3}{4}$ empty the battery symbol ② will flash as soon as the device is switched on (partly filled battery displayed). Although the device will continue to measure reliably, you should obtain replacement batteries.

Flat battery – replacement

When the batteries are flat, the battery symbol ② will flash as soon as the device is switched on (flat battery displayed). You cannot take any further measurements and must replace the batteries.

1. Open the battery compartment ⑤ on the bottom of the device.
 2. Replace the batteries – ensure correct polarity as shown by the symbols in the compartment.
 3. To set date and time, follow the procedure described in «Section 3.».
- ☞ The memory retains all values although date and time must be reset – the year number therefore flashes automatically after the batteries are replaced.

Which batteries and which procedure?

- ☞ Use 4 new, long-life 1.5 V, size AAA batteries.
- ☞ Do not use batteries beyond their date of expiry.
- ☞ Remove batteries if the device is not going to be used for a prolonged period.



Using rechargeable batteries

You can also operate this device using rechargeable batteries.

- ☞ Only use «NiMH» type reusable batteries.
- ☞ Batteries must be removed and recharged when the flat battery symbol appears. They should not remain inside the device as they may become damaged (total discharge as a result of low use of the device, even when switched off).
- ☞ Always remove the rechargeable batteries if you do not intend to use the device for a week or more.
- ☞ Batteries cannot be charged in the blood pressure monitor. Recharge batteries in an external charger and observe the information regarding charging, care and durability.

10. Using a Mains Adapter

You can operate this device using the **aponorm®** by microlife mains adapter (DC 6 V, 600 mA).

-  Only use the **aponorm®** by microlife mains adapter available as an original accessory appropriate for your supply voltage.
-  Ensure that neither the mains adapter or the cable are damaged.

1. Plug the adapter cable into the mains adapter socket ④ in the blood pressure monitor.
2. Plug the adapter plug into the wall socket.

When the mains adapter is connected, no battery current is consumed.

11. Error Messages

If an error occurs during the measurement, the measurement is interrupted and an error message, e.g. «**ERR 3**», is displayed.

Error	Description	Potential cause and remedy
« ERR 1 »	Signal too weak	The pulse signals on the cuff are too weak. Re-position the cuff and repeat the measurement.*
« ERR 2 » ⑦	Error signal	During the measurement, error signals were detected by the cuff, caused for instance by movement or muscle tension. Repeat the measurement, keeping your arm still.

Error	Description	Potential cause and remedy
« ERR 3 » ②	No pressure in the cuff	An adequate pressure cannot be generated in the cuff. A leak may have occurred. Check that the cuff is correctly connected and is not too loose. Replace the batteries if necessary. Repeat the measurement.
« ERR 5 »	Abnormal result	The measuring signals are inaccurate and no result can therefore be displayed. Read through the checklist for performing reliable measurements and then repeat the measurement.*
« ERR 5 »	AFIB/MAM-Mode	There were too many errors during the measurement in AFIB/MAM mode, making it impossible to obtain a final result. Read through the checklist for performing reliable measurements and then repeat the measurement.*
« Hl »	Pulse or cuff pressure too high	The pressure in the cuff is too high (over 300 mmHg) OR the pulse is too high (over 200 beats per minute). Relax for 5 minutes and repeat the measurement.*
« LO »	Pulse too low	The pulse is too low (less than 40 beats per minute). Repeat the measurement.*

* Please consult your doctor, if this or any other problem occurs repeatedly.

-  If you think the results are unusual, please read through the information in «Section 1.» carefully.

12. Safety, Care, Accuracy Test and Disposal



Safety and protection

- This device may only be used for the purposes described in this instruction. The manufacturer cannot be held liable for damage caused by incorrect application.
- This device comprises sensitive components and must be treated with caution. Observe the storage and operating conditions described in the «Technical Specifications» section.
- Protect it from:
 - ▶ water and moisture
 - ▶ impact and dropping
 - ▶ contamination and dust
 - ▶ direct sunlight
 - ▶ heat and cold
- The cuffs are sensitive and must be handled with care.
- Only pump up the cuff once fitted.
- Do not use this device close to strong electromagnetic fields such as mobile telephones or radio installations.
- Do not use this device if you think it is damaged or notice anything unusual.
- Never open this device.
- If the device is not going to be used for a prolonged period the batteries should be removed.
- Read the additional safety information in the individual sections of this instructions.



Ensure that children do not use this device unsupervised; some parts are small enough to be swallowed.

Device care

Clean the device only with a soft, dry cloth.

Cleaning the cuff

Carefully remove spots on the cuff with a damp cloth and soapsuds.



WARNING: Do not wash the cuff in a washing machine or dishwasher!

Accuracy test

We recommend this device is tested for accuracy every 2 years or after mechanical impact (e.g. being dropped). Please contact **aponorm**[®] by microlife-Service to arrange the test (see foreword).

Disposal



Batteries and electronic devices must be disposed of in accordance with the locally applicable regulations, not with domestic waste.

13. Guarantee

This device is covered by a **5 year guarantee** from the date of purchase. The guarantee is valid only on presentation of the guarantee card completed by the dealer (see back) confirming date of purchase or the receipt.

- Batteries and wearing parts are not included.
- Opening or altering the device invalidates the guarantee.
- The guarantee does not cover damage caused by improper handling, discharged batteries, accidents or non-compliance with the operating instructions.
- The cuff is included for the functional guarantee only (tightness) for 2 years.

Please contact **aponorm**[®] by microlife-Service (see foreword).

14. Technical Specifications

Operating temperature:	10 - 40 °C / 50 - 104 °F 15 - 95 % relative maximum humidity
Storage temperature:	-20 - +55 °C / -4 - +131 °F 15 - 95 % relative maximum humidity
Weight:	354 g (including batteries)
Dimensions:	160 x 80 x 32 mm
Measuring procedure:	oscillometric, corresponding to Korotkoff method: Phase I systolic, Phase V diastolic
Measurement range:	20 - 280 mmHg – blood pressure 40 - 200 beats per minute – pulse
Cuff pressure display range:	0 - 299 mmHg
Resolution:	1 mmHg
Static accuracy:	pressure within ± 3 mmHg
Pulse accuracy:	± 5 % of the readout value
Voltage source:	<ul style="list-style-type: none">• 4 x 1.5 V Batteries; size AAA• Mains adapter DC 6 V, 600 mA (optional)
Reference to standards:	EN 1060-1 /-3 /-4; IEC 60601-1; IEC 60601-1-2 (EMC)

This device complies with the requirements of the Medical Device Directive 93/42/EEC.

Technical alterations reserved.

aponorm® Professionell – Garantiekarte

Name of Purchaser / Nom de l'acheteur / Nombre del comprador / Nome do comprador /
Name des Käufers / Naam koper / Ф.И.О. покупателя / Imię i nazwisko nabywcy /
Vásárló neve / Име на купувача / Numele cumpărătorului / Jméno kupujícího /
Meno zákazníka / Alıcının Adı / Ονοματεπώνυμο αγοραστή

Serial Number / Numéro de série / Número de serie / Número de série / Serien-Nr. /
Seriennummer / Серийный номер / Numer seryjny / Sorozatszám / Сериен номер /
Număr de serie / Výrobné číslo / Seri Numarası / Αριθμός σειράς

Date of Purchase / Date d'achat / Fecha de compra / Data da compra / Kaufdatum /
Datum van aankoop / Дата покупки / Data zakupu / Vásárlás dátuma / Дата на
закупване / Data cumpărării / Datum nákupu / Dátum kúpy / Satın Alma Tarihi /
Ημερομηνία αγοράς

Specialist Dealer / Revendeur / Vendedor especializado / Revendedor autorizado /
Apotheker / Specialist Dealer / Специализированный дилер / Przedstawiciel /
Forgalmazó / Специалист дистрибутор / Distributor de specialitate / Specializovaný dealer /
Špecializovaný predajca / Uzman Satıcı / Εξειδικευμένος αντιπρόσωπος

Garantiekarte

Ihre Sicherheit: die aponorm® by microlife Garantie.

Ihr neues Blutdruckmessgerät ist ein medizinisches Präzisionsgerät der Spitzenklasse. Dafür verbürgen wir uns mit unserem guten Namen und unserer

5-Jahres-Garantie.

Die genauen Garantie-Bedingungen finden Sie auf Seite 13 der Gebrauchsanweisung.

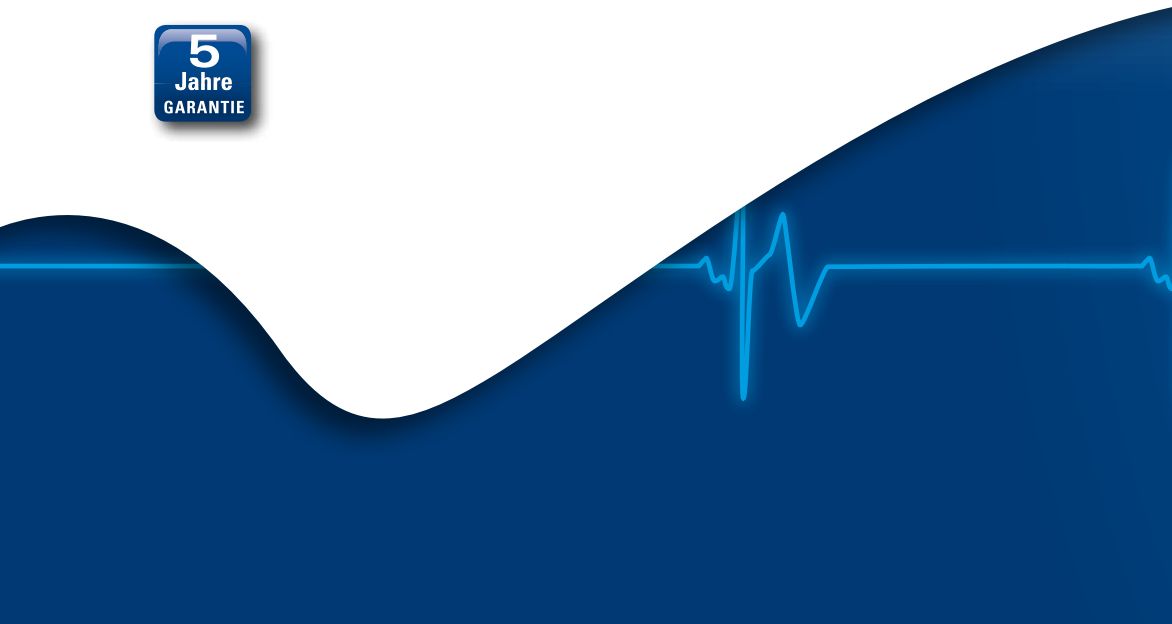

apornorm®

die marke der apotheke

WEPA

DIE APOTHEKENMARKE

Vertrieb durch:

WEPA Apothekenbedarf

GmbH & Co KG

Am Fichtenstrauch 6-10

56204 Hillscheid

www.apornorm.de

www.wepa-dieapothekenmarke.de



microlife®

Hersteller:

Microlife AG

Espenstraße 139

CH-9443 Widnau

www.microlife.ch

Hilfspositionsnummer 21.28.01.3044

Bestell-Nr. 46934



PZN - 02392151

CE 0044

