

Wall Mounting Instructions for the Diagnostix™ 750W



Tools Needed

- Medium phillips head screwdriver
- Hammer
- Drill with 3/16" drill bit

Directions

1. Position manometer (with attached wall bracket) on wall at desired location and rotate gauge to right side to permit access to left side mounting holes on bracket. Make pencil marks on wall through the mounting holes. Holding bracket firmly in place, rotate gauge to left side to permit access to right side mounting holes. Make pencil marks on wall through the mounting holes. Recommended height is near the eye level of the intended users.
2. At each of the four pencil marks, drill a 3/16" hole approximately 7/8" deep. Use a masonry type bit if drilling through ceramic tile.
3. Gently tap the 4 screw anchors into the holes until they are flush with the wall.
4. Position the manometer and bracket over the screw holes and screw bracket into wall first on one side, then the other using the procedure outlined in step one to gain access to each of the four mounting holes. Take care not to over tighten screws.
5. Attach 8 foot length of coiled tubing to air inlet at bottom of manometer. Insert "male" luer connector on free end of coiled tubing to "female" luer connector on bladder tubing. Wrap cuff around bulb and store in mounting bracket/storage compartment behind gauge.

Note: If the mounting hardware supplied is not suitable for the application, select hardware of adequate size and type to secure the instrument firmly to the wall.

Important: The instrument is designed to permit wall mounting without having to first remove the bracket from the instrument. If the instrument is removed from the bracket for mounting or service, we recommend applying removable loctite® to the bracket hardware to prevent the instrument from working loose. Loctite can be obtained from most hardware stores.

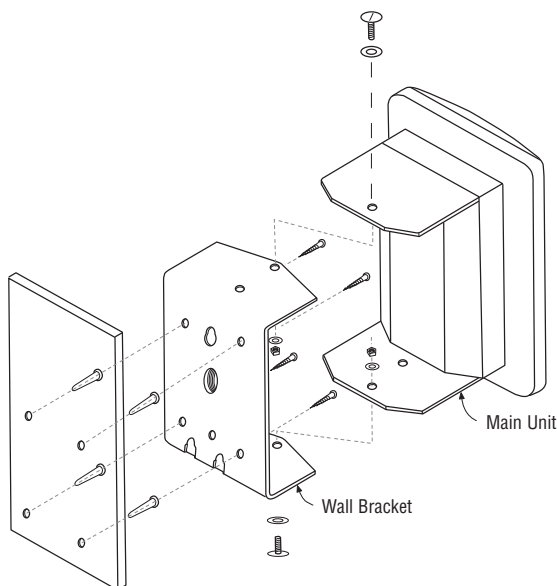

CAUTION: Ensure that the unit is securely mounted prior to use to avoid damage to the instrument and/or potential injury.

Diagnostix™ 752M, 750W Aneroids



- Mobile Aneroid Assembly Instructions
- Schematic
- Parts List for Mobile Stand
- Wall Aneroid Mounting Instructions



To Register Your Product,
visit us at
www.adctoday.com
and follow the links



55 Commerce Drive
Hauppauge, NY 11788
Customer Service: 1-800-ADC-2670
Voice: 1-631-273-9600
Fax: 1-631-273-9659
email: info@adctoday.com
<http://www.adctoday.com>
NEW YORK • LONDON • TOKYO
©2015 ADC® IB p/n: 9352B-00 - rev 6

Assembly Instructions for the Diagnostix™ 752M

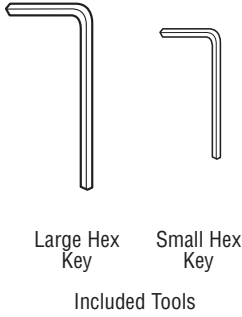

1. With base on its side connect upright outer pole to base using the long hex bolt. Tighten with the large hex key provided. Tighten hardware as securely as possible. (Note: To prevent loosening, hardware must be tightened securely and periodically checked). (Figure 1).

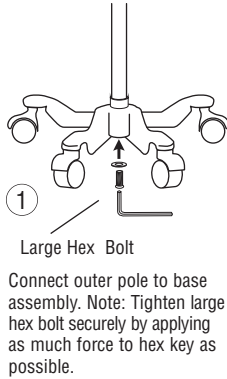

2. Slide stainless steel inner pole inside outer pole with open end up. (Figure 2).

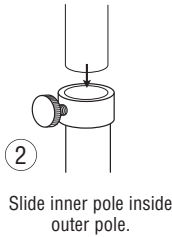

3. Loosen the hex bolt on collar of cuff storage basket with small hex key provided. Place cuff storage basket on top of stainless steel inner pole making sure the pole goes completely inside collar and tighten hex bolt with key. (Figure 3).

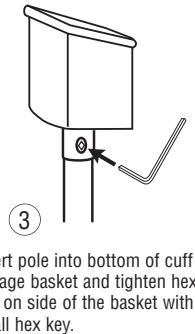

4. Attach manometer bracket to cuff storage basket using the short hex bolt and washers as shown. Tighten securely with large hex key. (Figure 4).

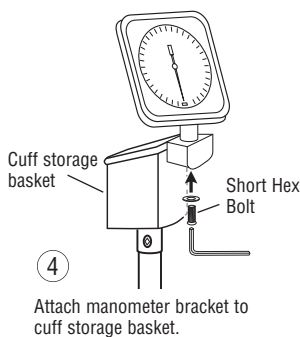

5. Adjust height of manometer by loosening knob and raising or lowering inner pole until gauge is at desired height. Tighten knob by hand.
6. Connect coiled tubing to gauge inlet. (Note: The coiled tubing may be difficult to connect, moisten with soapy water if necessary). Refer to booklet entitled DIAGNOSTIX™ Aneroids Pocket, Palm, Clock Type booklet (9350N-00) for instructions on operating the unit.

Schematic Parts List

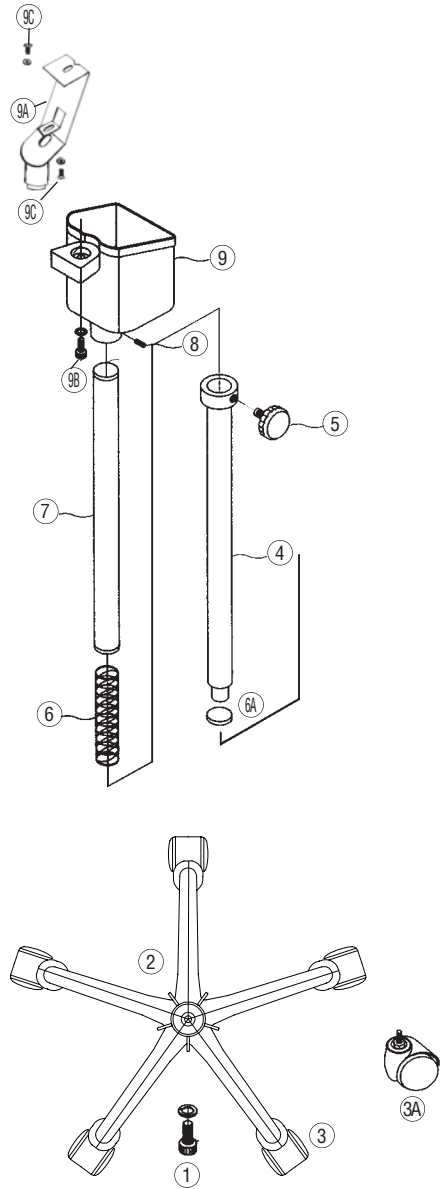

Mobile Stand Assembly for the 752M

Ref #	Item #	Description
1	972-101	Long Hex Bolt and Washer (1)
2	972-080	Base
3	972-106	Casters (5)
3A	972-106-1	Single Caster
4	972-107	Outer Pole
5	972-108	Knob
6	972-109	Spring
6A	972-107A	Gasket
7	972-110	Inner Pole
8	972-111	Tightening Device
9	972-112	Cuff Storage Basket
9A	752-113	Manometer Bracket
9B	752-114	Short Hex Bolt & Washer
9C	752-115	Manometer Bracket Hardware