

AND

A&D Medical

EASY ONE STEP

Blood Pressure Monitor









Trilingual Instruction Guide - MODEL UA-631V
English • Français • Español

THIS MONITOR IS CLINICALLY VALIDATED

This LifeSource blood pressure monitor has undergone and passed a Clinical Validation study to determine the performance and accuracy. This monitor is clinically validated according to the British Hypertension Society (BHS) standard. The BHS is the most prestigious international blood pressure organization. The published study was performed by a reviewing committee consisting of physicians and/or nurses.

IMPORTANT INFORMATION

Please read this important information before using your monitor.

-  Please remember that only a medical practitioner is qualified to interpret your blood pressure measurements. Use of this device should not replace regular medical examinations.
-  Have your physician review your procedure for using this device. He or she will want to verify blood pressure measurements before prescribing or adjusting medications.
-  Consult your physician if you have any doubt about your readings. Should a mechanical problem occur, contact A&D Medical.
-  Do not attempt to service, calibrate, or repair this monitor.
-  Because your UA-631V monitor contains delicate, high-precision parts, avoid exposing it to extremes in temperature or humidity or to direct sunlight, shock and dust. A&D Medical guarantees the accuracy of this monitor only when it is stored and used within the temperature and humidity ranges noted on page E-17.
-  Clean the monitor and cuff with a dry, soft cloth or a cloth dampened with water and a mild detergent. Never use alcohol, benzene, thinner or other harsh chemicals to clean monitor or cuff.
-  Remove and replace batteries if monitor is not used for more than **six months**. Alkaline batteries recommended.

PRECAUTIONS

The UA-631V is designed to be used at home, by those who are eighteen (18) years and older, to monitor blood pressure (systolic and diastolic) and pulse rate. It is not designed for ambulatory use.



LIFE SOURCE[®]

Fast. Easy. Accurate.

Congratulations on purchasing a state-of-the-art LifeSource[®] blood pressure monitor—one of the most technologically advanced monitors available today. Designed for ease of use and accuracy, this monitor will facilitate your daily blood pressure regimen.



Physicians agree that daily self-monitoring of blood pressure is an important step individuals can take to maintain cardiovascular health and prevent the serious consequences associated with undetected and untreated hypertension.



A&D Medical has been manufacturing high quality healthcare products for over 20 years. We are committed to providing you and your family with monitoring devices that provide the utmost in accuracy and convenience.

LifeSource - Designed for Life.

TABLE OF CONTENTS



WHAT DISPLAY SYMBOLS MEAN E-2
MONITOR COMPONENTS E-3
HOW UA-631V WORKS E-4



BEFORE YOU START E-4
SELECTING THE CORRECT CUFF SIZE E-5



TAKING YOUR BLOOD PRESSURE E-6 — E-7
WHAT IS AN IRREGULAR HEARTBEAT E-8
ABOUT CUFF INFLATION METER E-8
ABOUT AVERAGE READING E-9
ABOUT PRESSURE RATING INDICATOR™ E-9
ABOUT MEMORY E-10



ABOUT BLOOD PRESSURE E-11 — E-15







TROUBLESHOOTING E-16
SPECIFICATIONS E-17



CONTACT INFORMATION E-18

FRENCH INSTRUCTIONS F-1
SPANISH INSTRUCTIONS S-1

WHAT DISPLAY SYMBOLS MEAN

Display Symbol	Condition/Cause	Recommended Action
	The symbol shown while measurement is in progress. It blinks while detecting the pulse.	Measurement is in progress, remain as still as possible.
	An irregular heartbeat or body movement may have occurred. Refer to page E-8 for more information on irregular heartbeats.	Take measurement again and consult with your physician.
M	Previous measurement stored in MEMORY.	
 Battery Full	The battery power indicator during measurement.	Replace all batteries with new ones when the symbol blinks. Alkaline batteries recommended.
 Battery Low	The batteries are low when it blinks.	
<i>Err</i>	Unstable blood pressure due to excessive body movement.	Try the measurement again. Remain very still during the measurement.
	The systolic and diastolic values are within 10 mmHg of each other.	Fasten the cuff correctly, and try the measurement again.
	The pressure value did not increase during inflation.	Check for air leaks along the tube and around the air socket.
<i>Err</i> <i>CUF</i>	The cuff is not fastened correctly.	Refasten the cuff and retake measurement.
	There is an air leak in the cuff or monitor.	Make sure tube is properly connected to cuff and monitor.
<i>Err</i>	The pulse is not detected correctly. The symbol will appear on the pulse display area.	Try the measurement again. Remain very still during the measurement.
	Cuff Inflation Meter	Measurement is in progress, remain as still as possible
	Pressure Rating Indicator™	Refer to the section “About Pressure Rating Indicator” for further explanation.

MONITOR COMPONENTS

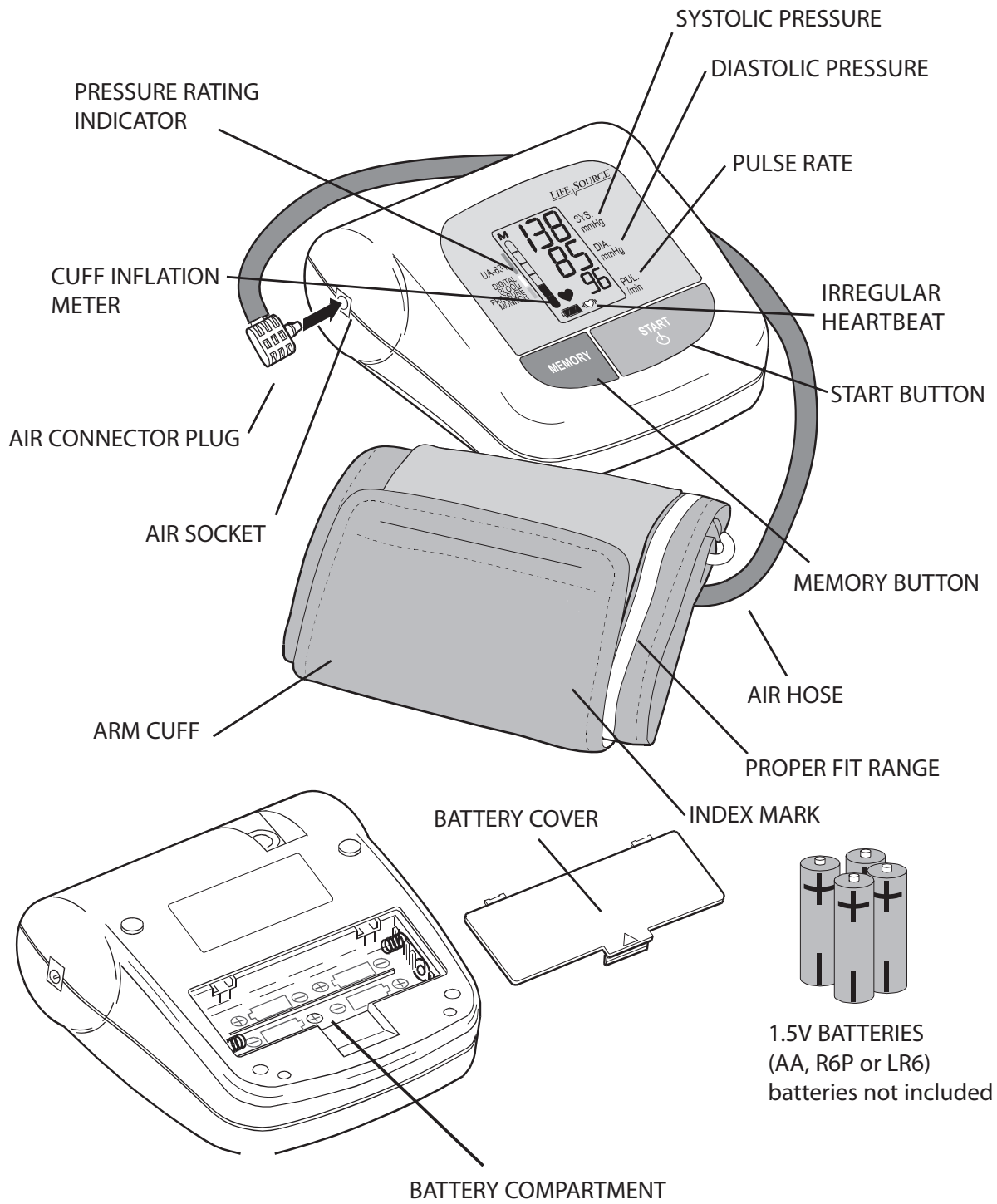

In Canada - Auto Control Medical (Toll-Free): 1-800-461-0991

E-3

HOW UA-631V WORKS

Lifesource blood pressure monitors are easy to use, accurate and digitally display full measurement readouts. Our technology is based on the “oscillometric method” – a noninvasive blood pressure determination. The term “oscillation” refers to any measure of vibrations caused by the arterial pulse. Our monitor examines the pulsatile pressure generated by the arterial wall as it expands and contracts against the cuff with each heartbeat.

The cuff is inflated until the artery is fully blocked. The inflation speed is maximized and the pressure level is optimized by the device. The monitor takes measurements while the cuff is both inflating and deflating. This results in a faster measurement providing greater comfort to the user.

BEFORE YOU START

You must install 4 type AA (1.5 volt) batteries not included (alkaline batteries recommended) and attach the cuff to the monitor before using it. To install batteries (or replace them if the “Low Battery” symbol appears on display), proceed as follows:

1. Remove battery compartment cover by gently pushing down on arrow and sliding cover forward.
2. Put in bottom row of batteries first. Place the batteries in compartment with positive (+) and negative (-) terminals matching those indicated in the compartment. Be sure batteries make contact with compartment terminals.
3. Replace cover by sliding it into the compartment and gently pressing into place.

NOTE: Rechargeable batteries will not work with this monitor.

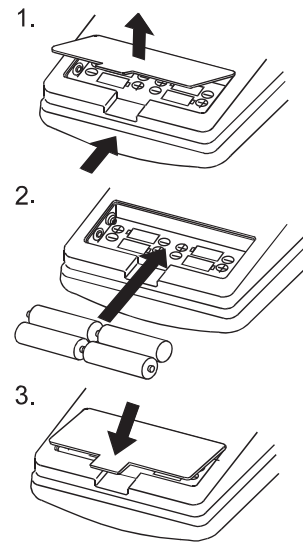

SELECTING THE CORRECT CUFF SIZE

Using the correct cuff size is important for an accurate reading. A cuff that is too large will produce a reading that is lower than the correct blood pressure; a cuff that is too small will produce a reading that is higher than the correct blood pressure. With your arm hanging at the side of your body, measure the circumference of your upper arm at the midpoint between the shoulder and elbow.

ARM SIZE	RECOMMENDED CUFF SIZE	REPLACEMENT CUFF MODEL#
6.3" - 9.4" (16-24cm)	Small Cuff	UA-279
9.4" - 14.2" (24-36cm)	Standard Cuff	UA-280
14.2" - 17.7" (36-45cm)	Large Cuff	UA-281

■ Cuff Size Indicator On The Cuff

Our cuff has an indicator which tells you whether you are using the correct cuff size or not. Place the cuff on your arm (see Page E-6 to learn how to put the cuff on correctly) and if the Index Mark ▲ points within the Proper Fit Range, you are using the correct cuff size.

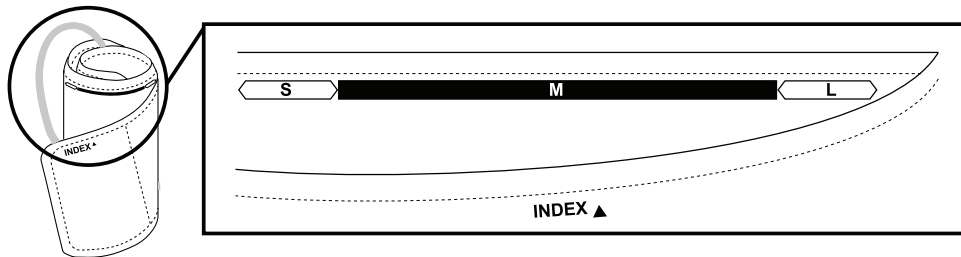







In Canada - Auto Control Medical (Toll-Free): 1-800-461-0991

E-5

TAKING YOUR BLOOD PRESSURE

Tips for Blood Pressure Monitoring:

-  Relax for several moments before measurement.
-  Do not smoke or ingest caffeine at least 30 minutes prior to measurement
-  Remove constricting clothing and place cuff on bare arm.
-  Unless your physician recommends otherwise, use left arm to measure pressure.
-  Do not talk during measurement.
-  Do not cross legs, and keep your feet flat on floor during measurement.

Now you are ready. Follow these simple steps:

1. Sit comfortably with your left arm resting on a flat surface so that the center of your upper arm is at the same height as your heart.
2. Lay left arm on the table, palm up and thread cuff end through metal loop, smooth side against arm. Then position the tube off-center toward the inner side of arm in line with the little finger.
3. Pull the end of the cuff to tighten it, fold back the extra material, and fasten securely. The cuff should be snug but not too tight. You should be able to insert two fingers between the cuff and your arm.

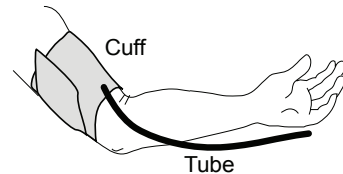

IMPORTANT: Measure pressure at the same time each day.

4. Confirm that the index  points within the proper fit range.

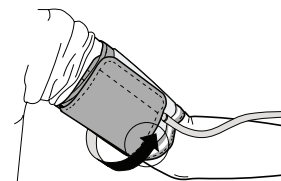
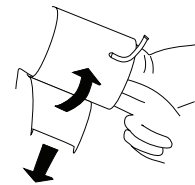

TAKING YOUR BLOOD PRESSURE

5. Press the START button. As the cuff pressurizes, measurement will begin and the Cuff Inflation Meter will show on the display screen. It is normal for the cuff to feel very tight.

NOTE: If an appropriate pressure is not obtained, the device automatically starts to inflate again.

NOTE: If you wish to stop inflation at any time, press the START button again.

6. When the inflation is complete, the deflation starts automatically and the ♥ symbol blinks, indicating that the measurement is in progress. Once the pulse is detected, the symbol flashes with each pulse beat.

NOTE: If an appropriate pressure is not obtained, the device automatically starts to inflate again.

7. When the measurement is complete, the systolic and diastolic pressure readings and pulse rate are displayed.

The cuff deflates and the monitor automatically shuts off after 60 seconds, or you can turn it off by pressing the START button.

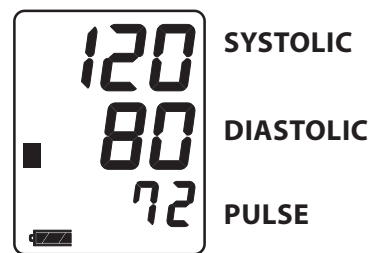

8. The reading is then stored into memory. See page E-10 for more details about the memory function.
9. Remove cuff and make a note of your blood pressure and pulse rate on the chart in the back of the manual, indicating date and time of measurement.

We advise that you record the date and time after each measurement because an accurate blood pressure history relies not on single or sporadic readings but on a pattern over time.

WHAT IS AN IRREGULAR HEARTBEAT

The UA-631V monitor provides a blood pressure and pulse rate measurement even when an irregular heartbeat occurs. The irregular heartbeat symbol «♥» will appear in the display window in the event an irregular heartbeat has occurred during measurement. An irregular heartbeat is defined as a heartbeat that varies by 25% from the average of all heartbeat intervals during the blood pressure measurement. It is important that you relax, remain still and refrain from talking during measurements.

NOTE: We recommend contacting your physician if you see this «♥» symbol frequently.

ABOUT CUFF INFLATION METER

The Cuff Inflation Meter is located on the left side of the display screen to tell you when the blood pressure monitor is inflating and deflating the cuff. The Cuff Inflation Meter moves up during inflation and moves down during deflation.

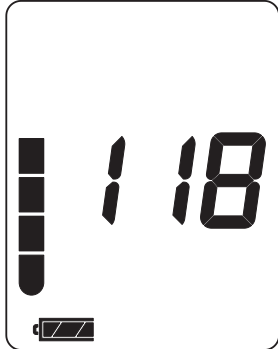
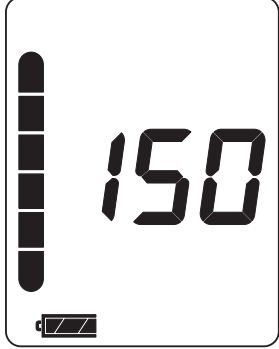
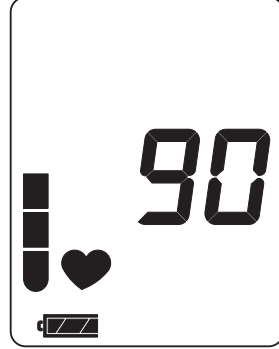
Inflation in Progress	Inflation Complete	Deflation/Measurement in Progress
		

ABOUT AVERAGE READING

The UA-631V provides an average blood pressure reading based on the total measurements stored in memory. When taking a measurement, the average blood pressure reading will appear and the number of measurements stored in memory will flash several times before the cuff begins to inflate.

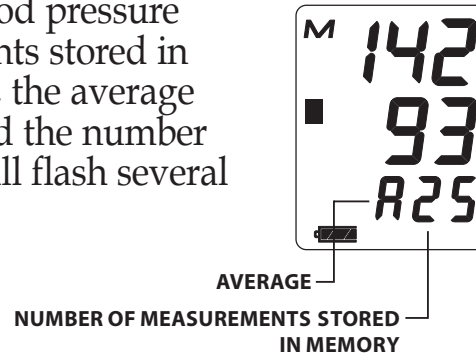

ABOUT PRESSURE RATING INDICATOR™

The Pressure Rating Indicator™ is a feature which provides a snapshot of your blood pressure classification based on your measurements. This will let you quickly know what your blood pressure readings mean. Each segment of the bar indicator corresponds to the Seventh Report of the Joint National Committee (JNC7) on Prevention, Evaluation and Treatment of High Blood Pressure from the National Heart, Lung and Blood Institute - May 2003. For a more detailed look at this blood pressure classification, please refer to "Assessing High Blood Pressure" on page E-12.

Pressure Rating Indicator™

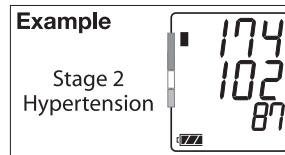
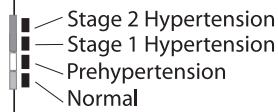

■: The indicator displays a segment, based on the current measurement, corresponding to the JNC7 Classification.

NOTE: Due to other risk factors (e.g. diabetes, obesity, smoking, etc.) in addition to your blood pressure measurement, the Pressure Rating Indicator is approximate. Please consult with your physician for interpretation and diagnosis of your blood pressure measurements.

NOTE: Residents outside of the United States (e.g., Canada and Mexico) should refer to the WHO Classification Table on page E-12 for assessment of their blood pressure measurement.

In Canada - Auto Control Medical (Toll-Free): 1-800-461-0991

E-9

ABOUT MEMORY

This monitor automatically stores up to sixty (60) blood pressure and pulse measurements in memory. Measurements stored in memory are assigned an index number in the order of the newest to the oldest. The oldest reading displays as “n01”. The M symbol in the upper left corner of the display screen indicates that you are viewing a previous measurement stored in memory.

To retrieve readings, follow these simple steps:

1. When the display screen is blank, press and quickly release the Memory button. You will see the index number of the most recent blood pressure that was taken followed by the measurement.
2. If you want to retrieve other measurements in memory, press and release the Memory button repeatedly until the desired index number is reached (e.g. n04). The measurement will then be displayed.
3. The display will shut off automatically a few seconds after the readings are displayed.

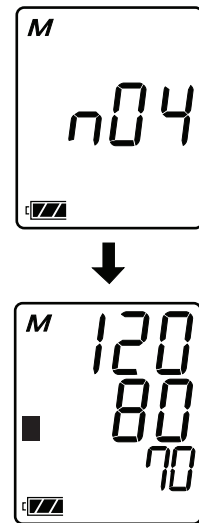

If there are no measurements stored in memory, you will see two 0s displayed vertically followed by a blinking “A00”.

To *clear* the measurement history from memory, press and hold the Memory button for at least five seconds while the display screen is showing blank. Release the Memory button when you see the M symbol in upper left hand corner of the display flash and disappears. This indicates that the memory has been cleared.

NOTE: Stored measurements, will be lost if batteries become low or are removed.

ABOUT BLOOD PRESSURE

■ What Is Blood Pressure?

Blood pressure is the force exerted by blood against the walls of the arteries. Systolic pressure occurs when the heart contracts; diastolic pressure occurs when the heart expands. Blood pressure is measured in millimeters of mercury (mmHg).

■ What Affects Blood Pressure?

Blood pressure is affected by many factors: age, weight, time of day, activity level, climate, altitude and season. Certain activities can significantly alter one's blood pressure. Walking can raise systolic pressure by 12 mmHg and diastolic pressure by 5.5 mmHg. Sleeping can decrease systolic blood pressure by as much as 10 mmHg.

In addition to these factors, beverages containing caffeine or alcohol, certain medications, emotional stress and even tight-fitting clothes can make a difference in the readings.

■ What Causes Variations In Blood Pressure?

An individual's blood pressure varies greatly from day to day and season to season. For hypersensitive individuals, these variations are even more pronounced. Normally, blood pressure rises during work or play and falls to its lowest levels during sleep.

Fluctuation within a day (case: 35 year old male)

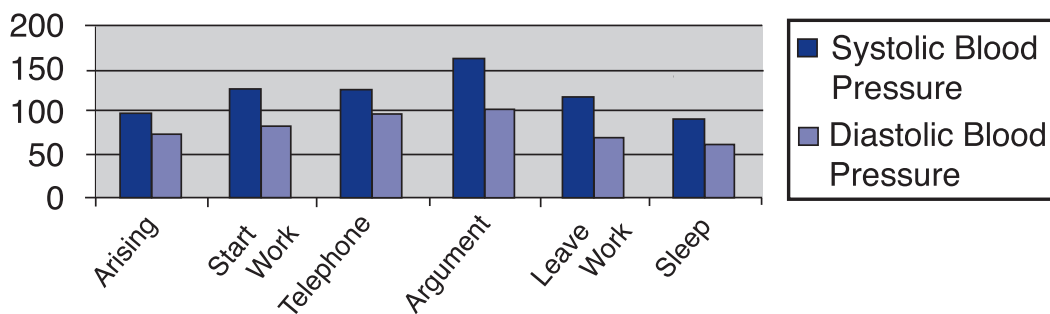

ABOUT BLOOD PRESSURE

■ Assessing High Blood Pressure for Adults

The following standards for assessing high blood pressure (without regard to age or gender) have been established as a guideline. Please note that other risk factors (e.g. diabetes, obesity, smoking, etc.) need to be taken into consideration and may affect these figures. Consult with your physician for an accurate assessment.

JNC7 Classification Table – for adults within the U.S.

BP Classification	Systolic (mmHg)		Diastolic (mmHg)
Normal	less than 120	and	less than 80
Prehypertension	120-139	or	80-89
Stage 1 Hypertension	140-159	or	90-99
Stage 2 Hypertension	greater than or equal to 160	or	greater than or equal to 100

SOURCE: The Seventh Report of the Joint National Committee on Prevention, Evaluation and Treatment of High Blood Pressure for Adults. National Heart, Lung and Blood Institute - May 2003.

WHO Classification Table – for adults outside of the U.S. (e.g. Canada, Mexico)

BP Classification	Systolic (mmHg)		Diastolic (mmHg)
Optimal	less than 120	and	less than 80
Normal	less than 130	or	less than 85
High-Normal	130-139	or	85-89
Stage 1 Hypertension	140-159	or	90-99
Stage 2 Hypertension	160-179	or	100-109
Stage 3 Hypertension	greater than or equal to 180	or	greater than or equal to 110

SOURCE: Standards to assess high blood pressure, without regard to age or gender, have been established by the World Health Organization (WHO).

E-12

LifeSource Health Line (Toll-Free): 1-888-726-9966

ABOUT BLOOD PRESSURE

■ What Is Hypertension?

Hypertension (high blood pressure) is the diagnosis given when readings consistently rise above normal. It is well known that hypertension can lead to stroke, heart attack or other illness if left untreated. Referred to as a “silent killer” because it does not always produce symptoms that alert you to the problem, hypertension is treatable when diagnosed early.

■ Can Hypertension Be Controlled?

In many individuals, hypertension can be controlled by altering lifestyle and minimizing stress, and by appropriate medication prescribed and monitored by your doctor. The American Heart Association recommends the following lifestyle suggestions to prevent or control hypertension:

- Don't smoke.
- Reduce salt and fat intake.
- Maintain proper weight.
- Exercise routinely.
- Have regular physical checkups.
- Monitor your blood pressure at periodic intervals.

■ Why Measure Blood Pressure at Home?

It is now well known that, for many individuals, blood pressure readings taken in a doctor's office or hospital setting might be elevated as a result of apprehension and anxiety. This response is commonly called “white coat hypertension.” In any case, self-measurement at home supplements your doctor's readings and provides a more accurate, complete blood pressure history. In addition, clinical studies have shown that the detection and treatment of hypertension is improved when patients both consult their physicians and monitor their own blood pressure at home.

In Canada - Auto Control Medical (Toll-Free): 1-800-461-0991

E-13

ABOUT BLOOD PRESSURE

■ Answers to Why Your Readings Are Different Between Home and at the Doctor's Office

Why are my readings different between home and at a doctor's office?

Your blood pressure readings taken in a doctor's office or hospital setting may be elevated as a result of apprehension and anxiety. This response is known as White Coat Hypertension.

When I bring my monitor to a doctor's office, why do I get a different measurement from my monitor to that taken by a doctor or nurse?

The healthcare professional may be using a different sized cuff. The size of the bladder inside the cuff is critical for the accuracy of the measurement. This may give you a different reading. A cuff too large will produce a reading that is lower than the correct blood pressure; a cuff that is too small will produce a reading that is higher than the correct blood pressure. There may also be other factors that can cause the difference in measurements.

■ Keys to Successful Monitoring:

Blood pressure fluctuates throughout the day. We recommend that you are consistent in your daily measurement routine:

- Measure at the same time every day.
- Sit in the same chair/position.
- Do not cross legs and keep your feet flat on the floor.
- Relax for several moments before measurement.
- Use the correct cuff size to get an accurate reading.
- Sit still during measurement - no talking, eating or sudden movements.
- Record your measurement in a logbook.

E-14

LifeSource Health Line (Toll-Free): 1-888-726-9966

ABOUT BLOOD PRESSURE

■ Establishing Baseline Measurements

The most important method to get an accurate blood pressure measurement is consistency. To get the most benefit out of your monitor, it is important to establish a “baseline measurement.” This helps build a foundation of measurements that you can use to compare against future readings. To build this baseline measurement, devote two weeks for consistent blood pressure monitoring. This involves doing everything the same way when you measure (e.g. measuring during the same time of day, in the same location, sitting in the same chair, using the same cuff, etc.). Once you establish your baseline measurement, you can start evaluating if your measurement has been affected based on lifestyle changes or medication treatment.

■ How Do I Record My Blood Pressure?

Blood pressure readings are typically recorded with the systolic pressure written first, followed by a slash mark and the diastolic pressure. For example, 120 mmHg systolic and 80 mmHg diastolic measurements are written as 120/80. Pulse is simply written with the letter “P” followed by the pulse rate – P 72, for example. Please see the back of the manual for the blood pressure tracking record.

■ Customer Support Tools Online

Additional tools are available on www.LifeSourceOnline.com to help you get the most out of your blood pressure monitoring.

These include:

- Large Print Instruction Manuals
- Animated Operating Instructions for select models
- Additional Logbook Sheets

In Canada - Auto Control Medical (Toll-Free): 1-800-461-0991

E-15

TROUBLESHOOTING

Problem	Probable cause	Corrective action
Nothing appears in the display, after I press the START button.	Batteries are drained.	Replace all batteries with new ones. Alkaline batteries recommended.
	Battery terminals are not in the correct position.	Reinstall the batteries with negative and positive terminals matching those indicated in the battery compartment.
The cuff does not inflate.	Battery voltage is too low. Low battery symbol blinks. [If the batteries are drained completely, the mark does not appear.]	Replace all batteries with new ones. Alkaline batteries recommended.
The unit does not measure. Readings are too high or too low.	The cuff is not fastened properly.	Fasten the cuff correctly.
	You moved your arm or body during the measurement.	Make sure you remain very still and quiet during the measurement.
	The cuff position is not correct.	Sit comfortably and still. Make sure the cuff is at the same level as your heart.
	You are using the wrong size cuff.	See Pg. E-5 "Selecting the Correct Cuff."
The value is different from that measured at a clinic or doctor's office.	The healthcare professional may be using a different sized cuff.	See Pg. E-14 "Answers to Why Your Readings Are Different Between Home and the Doctor's Office."
	Your measurements may be elevated by white coat hypertension	See Pg. E-13 "Why Measure Blood Pressure at Home."

NOTE: If the actions described above do not solve the problem, call 1-888-726-9966. Do not attempt to repair the device yourself as this may void your warranty.

SPECIFICATIONS

Model	UA-631V
Type	Oscillometric
Display	Digital, 15/10-mm character height Pressure/pulse displayed simultaneously
Memory	60 readings
Measurement range	Pressure: 20 mmHg to 280 mmHg Pulse: 40 pulses to 180 pulses
Accuracy	Pressure: ± 3 mmHg or $\pm 2\%$, whichever is greater Pulse: $\pm 5\%$
Pressurization	Automatic, using micropump
Depressurization	Constant air release valve system
Power source	4 type "AA" (1.5 volt) manganese batteries (not included) or 120V AC Adapter
Battery life	Approximately 300 measurement
Operating environment	50°F to 104°F (10°C to 40°C) Less than 85% relative humidity
Storage environment	-14°F to 140°F (-10°C to 60°C) Less than 95% relative humidity
Dimensions	Length: 5.1" (130 mm) Width: 5.7" (144 mm) Height: 2.2" (55 mm)
Weight	10.6 oz. (300 g) without batteries

Blood pressure measurements determined by the UA-631V are equivalent to those obtained by a trained observer using the cuff/stethoscope auscultation method within the limits prescribed by the American National Standards Institute for electronic or automated sphygmomanometers.

In Canada - Auto Control Medical (Toll-Free): 1-800-461-0991

E-17

CONTACT INFORMATION

Our products are designed and manufactured using the latest scientific and technological methods, and offer accurate, easy to use, home monitoring and treatment options. Our full product line includes:

- **Digital Blood Pressure Monitors**
- **Manual Blood Pressure Kits**
- **Blood Pressure Cuffs**
- **Stethoscopes**
- **Personal Health Scales**
- **Digital Thermometers**

This LifeSource blood pressure product is covered by a Five Year Warranty.

Visit our web site at www.LifeSourceOnline.com for warranty information.

For more information regarding use, care or servicing of your blood pressure monitor, contact:

A&D Medical

A division of A&D Engineering, Inc.

1756 Automation Parkway

San Jose, CA 95131

LifeSource Health Line (Toll-Free): 1-888-726-9966

www.LifeSourceOnline.com

IMPORTANT!

If You Need Assistance with the Set-Up or Operation

We Can Help!

Please call us **FIRST** before contacting your retailer at

LifeSource Health Line

1-888-726-9966 - Toll Free

A specially trained representative will assist you

A division of A&D Engineering, Inc.

1756 Automation Parkway

San Jose, CA 95131

1-888-726-9966

www.LifeSourceOnline.com

Pressure Rating Indicator is a trademark and LifeSource is a registered trademark of A&D Medical. Pressure Rating Indicator is patent pending.

© 2009 A&D Medical. All rights reserved.

Specifications subject to change without notice.

Printed in China

I-MAN:631V 8/09



LIFE SOURCE[®]

BLOOD PRESSURE RECORD JOURNAL DE LA TENSION ARTÉRIELLE REGISTRO DE LA PRESION ARTERIAL

Name :
Nom :
Nombre:

Age :
Âge :
Edad:

Weight :
Poids :
Peso:

DATE	AM	SYS/DIA	PULSE	PM	SYS/DIA	PULSE
DATE	AM	SYS/DIA	POULS	PM	SYS/DIA	POULS
FECHA	AM	SIS/DIA	PULSO	PM	SIS/DIA	PULSO